OPERATION MANUAL

TH2516 Series DC Resistance Meter

Changzhou Tonghui Electronic Co. , Ltd.

Add: No.3, Tianshan Road, New District, Changzhou, Jiangsu

Tel: (0519) 85132222, 85113342

Fax: (0519) 85109972

E-mail: Sales@tonghui.com.cn

Website: [http:// www.tonghui.com.cn](http://www.tonghui.com.cn)

Contents

1)	Introduction to Instrument, Unpacking and Installing.....	1
1.1	Introduction to Instrument.....	1
1.2	Unpacking.....	1
1.3	Power Connection.....	1
1.4	Fuse.....	2
1.5	Environment.....	2
1.6	Use of Test Fixture.....	2
1.7	Warm-up.....	2
1.8	Other Features.....	3
2)	Introduction to Front and Rear Panels.....	4
2.1	Introduction to Front Panel.....	4
2.2	Introduction to Rear Panel.....	5
2.3	Display Zone.....	6
2.4	Introduction to Buttons on Front Panel.....	7
2.4.1	[MEAS].....	7
2.4.2	[SYSTEM].....	7
2.5	Simple Operation.....	8
2.6	Starting Up.....	8
3)	Basic Operation.....	9
3.1	<MEAS DISP>.....	9
3.1.1	Measurement Functions.....	9
3.1.2	Measurement Range.....	10
3.1.3	Measurement Speed.....	10
3.1.4	File Manage.....	11
3.1.5	Tools.....	11
3.2	<COMP DISP>.....	12
3.2.1	File Manage.....	12
3.2.2	Tools.....	13
3.2.3	COMP (ON/OFF).....	13

3.2.4	Compare Mode and SETTINGS of ABS & Percent Error.....	13
3.3	<BIN DISP>	14
3.4	STATIS DISP	15
3.4.1	Edge Mode and Settings of Its Relevant Values	15
3.4.2	Status ON/OFF	16
3.4.3	Parameters of Statistic Analysis	16
3.4.4	TOOLS	17
3.4.5	FILE.....	17
3.5	<MEAS SETUP>	18
3.6	<TC/ Δ t SETUP> (TH2516).....	19
3.6.1	Temperature Correction (TC)	19
3.6.2	Temperature conversion (Δ t)	20
3.6.3	Types of Temperature Sensor	21
3.6.4	Parameter Setting.....	22
3.6.5	File	22
3.7	<BIN SETUP>	23
4)	System Setup and File Manage	24
4.1	System Setup	24
4.1.1	Tools	24
4.1.2	TouchTone	25
4.1.3	Language.....	25
4.1.4	Password.....	25
4.1.5	Bus Mode.....	26
4.1.6	Baud Rate.....	26
4.1.7	AC Freq	26
4.1.8	Handler VCC.....	26
4.1.9	LCD Style	27
4.1.10	Setting Time and Date	27
4.2	<File Manage>	27
4.2.1	Introduction to Save/Recall	27

4.2.2	Structure of File Folder/File in a U Disk.....	28
5)	Performance Index.....	32
5.1	Measurement Function.....	32
5.1.1	Measurement Parameters and Notations.....	32
5.1.2	Measurement Groups.....	32
5.1.3	Range.....	32
5.1.4	Trigger.....	32
5.1.5	Mode of Test Terminal.....	32
5.1.6	Resistance Measurement Time.....	33
5.1.7	Average.....	33
5.2	Test Signal.....	33
5.2.1	Current range.....	33
5.2.2	Output Voltage of Open Circuit.....	33
5.2.3	Maximum Display Range.....	33
5.3	Measurement Accuracy.....	34
5.3.1	Basic Accuracy for Resistance Measurement.....	34
5.3.2	Accuracy for Resistance Tested at Low Current Mode.....	35
5.3.3	Accuracy for Temperature Measurement (Pt500).....	35
5.3.4	Accuracy for Temperature Measurement (Analog Input).....	36
5.3.5	Temperature correction factor.....	36
6)	Remote Control.....	37
6.1	RS232C Connection.....	37
6.2	USBTMC Remote Control System.....	38
6.2.1	System Configuration.....	38
6.2.2	Install the Driver.....	38
6.3	USBVCOM Virtual Serial Port.....	39
6.3.1	System Configuration.....	40
6.3.2	Installing Driver.....	40
7)	SCIP Command Reference.....	41
7.1	TH2516 Subsystem Commands.....	41

7.1.1	DISPlay Subsystem Commands.....	41
7.1.2	FUNCTion Subsystem Commands	42
7.1.3	APERture Subsystem Commands	46
7.1.4	TRIGger Subsystem Commands.....	46
7.1.5	FETCH? Subsystem Commands	48
7.1.6	TEMPerature Subsystem Commands (TH2516)	49
7.1.7	COMParator Subsystem Commands	52
7.1.8	BIN Subsystem Commands.....	55
7.1.9	STATistics Subsystem Commands.....	59
7.1.10	SYSTem Subsystem Commands.....	64
8)	Handler Interface	67
9)	Package Contents and Warranty.....	69
9.1	Package Contents	69
9.2	Marks.....	69
9.3	Package.....	69
9.4	Shipping	70
9.5	Storage.....	70
9.6	Warranty.....	70

Declaration

The descriptions contained in this manual may not cover all information about this instrument. Introductions to the improvements of the instrument in performance, function, internal structure, outer appearance, accessories, packing material, etc. are subject to change without notice. If you find any inconformity of this manual with our instruments, please contact us for further consultation by the address listed on the cover.

1) Introduction to Instrument, Unpacking and Installing

Thank you for your purchase and use of our products! This chapter will introduce the basic instrument performance, which is followed by notes of unpacking and installing.

1.1 Introduction to Instrument

TH2516 adopts 32 bits CPU and high density SMD technology. 24 bits, 4.3-inch and touch LCD screen brings ease for your eyes and convenience to your operation. The maximum 0.05% accuracy and minimum 1 $\mu\Omega$ resolution shore up its leading role in testing relay contact resistance, interconnecting resistance, conductor resistance, PCB resistance and welding-hole resistance. Temperature compensation and conversion functions make your tests be free from the effect of the environment temperature. The offset voltage compensation has effectively eliminated the electromotive force of the DUT and its contact potential difference. For the contact influence of the thermoelectricity on DUT, its elimination is achieved; especially when the resistance changes with the temperature greatly, better test results will be achieved. With statistic analysis function, the instrument can make statistic analysis for a large number of test data.

TH2516 series is a powerful test tool for all kinds of resistor design, detection, quality control and production. Automation on production lines can be greatly improved by the realization of ultra-high test speed and the signal output of 3 compare results through HANDLER interface. With multiple output data display, comparison mode and bin comparator, TH2516 series can meet different test requirements of different resistor manufacturers. The prominent performance makes the test results come up to IEC and IML standard.

1.2 Unpacking

Inspect the shipping container for damage after unpacking it. It is not recommended to power on the instrument in the case of a damage container.

If the contents in the container do not conform to the packing list, notify us or your dealer.

1.3 Power Connection

- 1) Power supply: 90V-125V, 190V-250V
- 2) Power supply frequencies: 50Hz and 60Hz
- 3) Power supply power range: $\leq 30\text{VA}$
- 4) L (line wire), N (neutral wire) and E (earth ground wire) of the power supply input socket

should correspond to the power plug of the instrument.

- 5) The instrument has been specially designed for decreasing noise jamming caused by the input in AC power terminal, but it is also recommended to use it in the environment of low noise. If noises cannot be avoided, install a power source filter please.
-

WARNING: To avoid injury to personnel and damage to the instrument resulting from electric shock, do sure that the earth ground wire is safely grounded.

There is selector switch between 110V and 220V voltage besides the power interface on the rear panel. Please switch correctly.

1.4 Fuse

The fuse is a standard configuration, so use the included custom fuse please.

1.5 Environment

- 1) Do not store or use the instrument where it could be exposed to many dusts, great vibration, direct sunshine and corrosive gas.
- 2) Working condition:
Temperature: 0°C to 40°C Relative humidity: ≤ 80% No condensation
Storage condition:
Temperature: -10°C to 50°C Relative humidity: ≤ 90% No condensation
- 3) For high accuracy, do not block the left air vent so as to ensure good ventilation.
- 4) The instrument has been specially designed for decreasing noise jamming caused by the AC power input, but it is also recommended to use it in the environment of low noise. If noise cannot be avoided, install a power filter please.
- 5) Test leads on the instrument that are connected to DUTs should be kept away from strong electromagnetic fields to avoid interference.

1.6 Use of Test Fixture

Only use the test fixture or cable made by our company, because **the use of other test fixtures or cables may result in incorrect measurement results**. In addition, for good contact of DUT and fixture, keep the test fixture or cable and pins of DUT clean.

Connect the test fixture or cable to HI and LO terminals on the instrument front panel. Ensure the color and arrow conformity of the test fixture with that of sockets on panels, thus to avoid abnormal measurement.

1.7 Warm-up

- 1) For accurate measurement, the warm-up time should not be less than 30 minutes.

- 2) Do not turn on or off the instrument frequently. This may cause internal data confusion.

1.8 Other Features

- 1) Consumption: $\leq 30\text{VA}$
- 2) Dimensions (W*H*D): 235mm*105mm*360mm; this dimension is the final packaging size.
- 3) Weight: Approx. 3.6kg

2) Introduction to Front and Rear Panels

This chapter will describe the basic operation of TH2516. Before using the instrument, please read this chapter carefully.

2.1 Introduction to Front Panel

Figure 2-1 shows the front panel of TH2516.

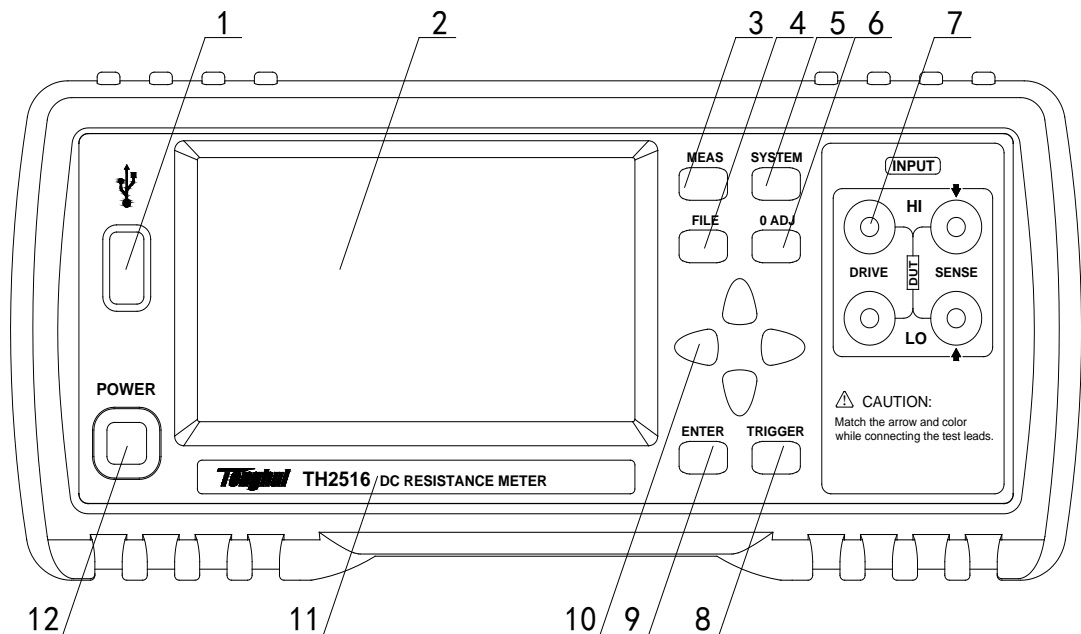

Figure 2-1 Front Panel

- 1) **USB interface**
HOST interface of USB
- 2) **LCD and touch screen**
480*272 dot-matrix, 24-bit, 4.3-inch TFT and touch LCD is used for measurement setup and result display.
- 3) **[MEAS]**
Press [MEAS] to enter into the MEAS DISP page.
- 4) **[FILE]**
Press [FILE] to enter into the page of internal and external File Manage.
- 5) **[SYSTEM]**
Press [SYSTEM] to enter into the SYSTEM SETUP page.
- 6) **[0 ADJ]**
Press [0 ADJ] to execute correction function.
- 7) **Test terminals (INPUT)**
4-terminal test terminal is used to measure DUT by a 4-terminal test cable.
The color and arrow of the test cable should correspond to that of socket on panel, thus to

avoid abnormal measurement.

8) [TRIGGER]

When the trigger mode is set as MANU (manual), pressing this key can trigger the instrument manually.

9) [ENTER]

Press this key to terminate and store input data.

10) Universal Arrow Keys

There are four arrow keys: up, down, left and right arrow keys.

11) Trademark and Model

Show instrument trademark and model.

12) POWER

It is the power switch.

2.2 Introduction to Rear Panel

Figure 2-2 shows the rear panel of TH2516.

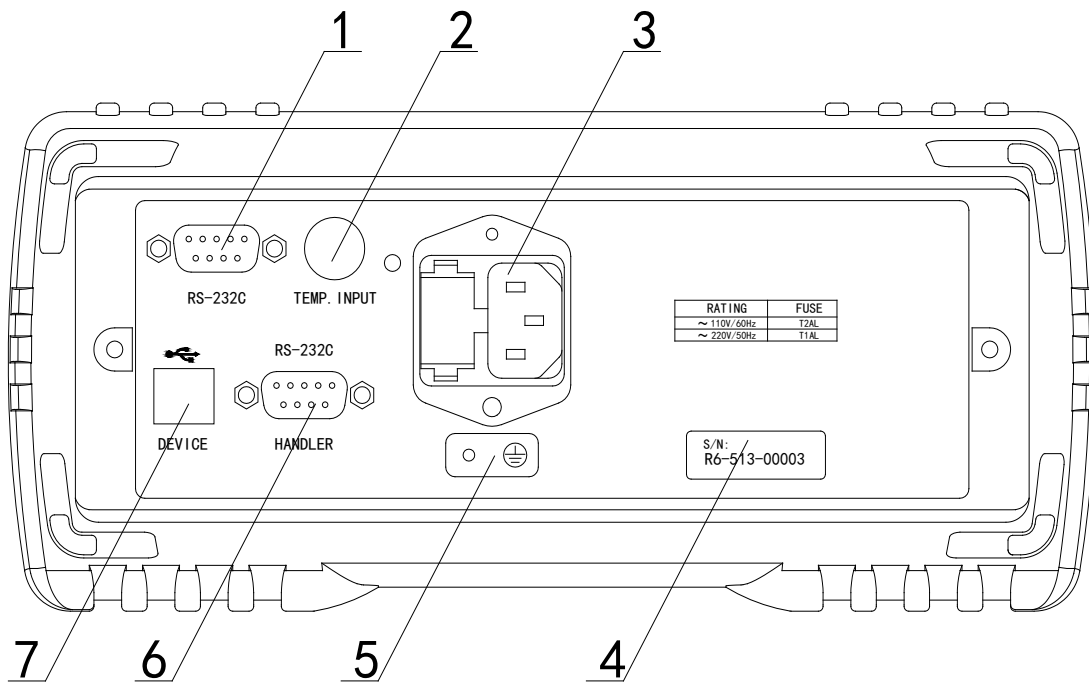

Figure 2-2 Rear Panel

1) RS232C Serial Interface

It realizes serial communication of the instrument with PC.

2) TEMP.INPUT

There are two kinds of temperature signal input: Pt500 and Analog Input.

3) Fuse socket and Power Socket

Fuse will be placed in this socket to protect the instrument; be used to input AC power.

4) Nameplate

It shows the instrument model.

5) Ground Terminal

This terminal connects the instrument chassis thus to protect or shield ground connection.

6) HANDLER Interface

Through HANDLER interface, an automatic test system can be conveniently constructed to realize auto test. TH2516 series will output bin comparator result signals and handshake signals by this interface, meanwhile, external trigger signal will also be sent to the instrument by it.

7) USB Interface

PC can remotely control TH2516 series through USB DEVICE.

2.3 Display Zone

TH2516 series adopts 24-bit 4.3-inch LCD touch screen with a resolution of 480*272. The display screen is divided into the following zones, as shown in figure 2-3.

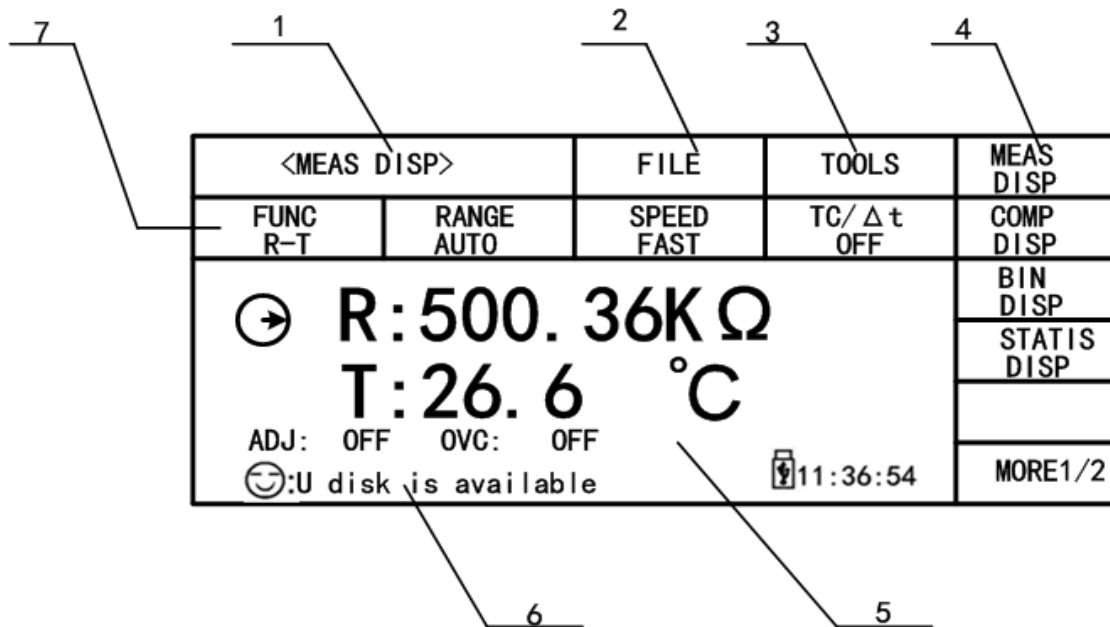

Figure 2-3 Display zone

1. Page name

This zone shows the current page name.

2. FILE

In this zone, file manage can be executed such as File Manage, Screen Copy.

3. TOOLS

This zone can set some short-cut functions.

4. Soft keys

This zone displays the function menu corresponding to the cursor-located zone.

5. Result display

This zone displays the measurement result such as resistance and temperature.

6. Prompt information

This zone displays all prompt information.

7. Function zone

This zone is used to change the measurement mode and measurement parameters.

2.4 Introduction to Buttons on Front Panel

2.4.1 [MEAS]

Press <MEAS> to enter into display homepage. Selectable functions in this page are shown as follows:

<MEAS DISP>

<COMP DISP>

<BIN DISP>

<STATIS DISP>

< >

<MORE 1/2>

<MEAS SETUP>

<TC/ Δ t SETUP> (TH2516)

<BIN SETUP>

<SYSTEM SETUP>

< >

<MORE 2/2>

2.4.2 [SYSTEM]

Press the [SYSTEM] button to enter into the <SYSTEM SETUP> page; the following soft keys will be displayed:

<MEAS DISP>

<COMP DISP>

<BIN DISP>

<STATIS DISP>

< >

<MORE 1/2 >

<MEAS SETUP>

<TC/ Δ t SETUP> (TH2516)

<BIN SETUP>

<SYSTEM SETUP>

< >

<MORE 2/2 >

2.5 Simple Operation

Simple operation steps for TH2516:

- Use [MEAS], [SYSTEM] or [FILE] or soft keys to enter into the page required to enter. (Refer to figure 3-1)
- Use arrow buttons ([←] [↑] [→] [↓]) to move the cursor to desired zone.
- When the cursor is moved to a soft key zone, press ENTER to confirm the selection. If it is required to input a number or a file name, use the keyboard to input and press ENTER to finish entry. You can use arrow buttons to select a number or a letter.

TH2516 touch screen operation is much easier. Just use your finger to touch the corresponding function on the screen and then the corresponding work will be done.

NOTE: DO NOT use acute units or nails to touch the screen. Doing so will cause damage to the screen, our company shall not be liable to this case.

2.6 Starting Up

Ensure the power earth (ground) wire is grounded, plug into a 3-wire power socket. Press down the power switch on the bottom left corner of the front panel, the instrument will be started up and a boot screen will be displayed.

Figure 2-4 shows the boot screen of TH2516, indicating product information such as instrument trademark, model and version.



Figure 2-4 TH2516 Boot Screen

If the password protection is enabled, you will be asked to input your password. After inputting your password, press [ENTER] to enter into the main menu page.

NOTE: This series of products have enabled password protection and the default password is 2516. You can reset the password by yourself. Refer to the password function on <SYSTEM SETUP> page for more details.

3) Basic Operation

3.1 <MEAS DISP>

Touch the screen or press down [MEAS], the <MEAS DISP> page will be displayed in the screen shown as figure 3-1.

<MEAS DISP>		FILE	TOOLS	MEAS DISP
FUNC R-T	RANGE AUTO	SPEED FAST	TC/Δt OFF	COMP DISP
				BIN DISP
				STATIS DISP
				MORE1/2

Figure 3-1 Measure Display

The following measurement parameters can be set on this page.

- Measurement function (**FUNC R-T**)
- Resistance range (**RANGE AUTO**)
- Measurement speed (**FAST SLOW1**)
- Measurement temperature (**TC/Δt**)
- File manage (**FILE**)
- Other tools (**TOOLS**)
- Soft keys (used to enter into operation pages)

The following test conditions are displayed in the measurement result/condition display area on this page. These conditions can be set on the tool function page of <MEAS SETUP> or <MEAS DISP> page.

0 ADJ (ON/OFF):

ON: turn on the function of SHORT zero clearing (self-calibration function)

OFF: turn off the function

OVC (ON/OFF): compensation of the offset voltage, i.e. compensation of the measurement error due to thermoelectromotive force on the DUTs. (TH2516/TH2516A)

3.1.1 Measurement Functions

Measurable parameters on TH2516 are as follows:

- R (Resistance)

- R-T (Resistance and temperature)
- T (Temperature)
- LPR (resistance test at low current mode)
- LPR-T (Temperature and resistance test at low current mode)

Note: Settings and modifications of all functions can be taken by the following steps:

1. Touch the corresponding function zone and then select the desired soft keys.
2. Use arrow buttons and [ENTER] button to set and modify the corresponding function.

Setting steps for measurement function:

You use buttons or touch the screen to select **FUNC**, available soft keys will be displayed in the right soft key zone.

- R
- R-T (TH2516)
- T (TH2516)
- LPR
- LPR-T (TH2516)

3.1.2 Measurement Range

There are two resistance modes: resistance measurement mode and resistance measurement at low voltage mode. Measure and display two types of parameters: resistance parameters and temperature parameters.

TH2516 has 9 DC resistance ranges: **20mΩ, 200mΩ, 2Ω, 20Ω, 200Ω, 2kΩ, 20kΩ, 200kΩ, 2MΩ**

TH2516A has 7 DC resistance ranges: **200mΩ, 2Ω, 20Ω, 200Ω, 2kΩ, 20kΩ, 200kΩ**

TH2516B has 7 DC resistance ranges: **20mΩ, 200mΩ, 2Ω, 20Ω, 200Ω, 2kΩ, 20kΩ**

TH2516, TH2516A, TH2516B has 4 DC low voltage resistance ranges: **2Ω, 20Ω, 200Ω, 2KΩ**

TH2516 The testing range of temperature (PT500): **-10°C to 99.9°C**.

The testing range of temperature (Analog): **0 to 2V**

Operation steps for setting measurement ranges:

- 1) Touch the range zone, the following soft keys will be displayed.
 - **AUTO** Set the range mode as AUTO.
 - **HOLD** Switch the range mode from AUTO to HOLD. When the range mode is set as HOLD, the range will be locked at the current measurement range which is displayed in the **RANG** zone.
 - **↑ (+)** Increase the range.
 - **↓ (-)** Decrease the range.
- 2) Touch the corresponding soft key to select the required range.

3.1.3 Measurement Speed

TH2516 displays the measurement result as a 5-digit number in the decimal point floating mode.

The measurement result of the speed is shown as a 4-digit number with one digit after the decimal point.

1) Touch the speed zone, the following soft keys will be displayed.

- **FAST**
- **MED**
- **SLOW1**
- **SLOW2**

2) Use above soft keys to modify the speed.

3.1.4 File Manage

1) Touch **FILE**, the following soft keys will be displayed.

- **File Manage:** Touch this key to enter into the file operation page.
- **Screen Copy:** Touch this key to capture the current screen and save it to a U disk in image format. Before a U disk is inserted, the save function will be disabled.
- **Save Data OFF:** Touch this key, this key will turn to <Save Data ON> and each measurement result will be continuously saved to the .CSV file in U disk. Before a U disk is inserted, the save function will be disabled. Press the key again, this key will turn to <Save Data OFF> and the measurement result will not be saved. When switching between ON and OFF once, a new .CSV file will be created in a U disk. The measurement data can be analyzed by opening the file through the computer.

2) As for File Manage, please refer to 4.2 for details.

3.1.5 Tools

Operation steps for setting tools:

Touch **TOOLS**, the following soft keys will be displayed in the soft key zone.

- **Display (ON/OFF):** Display the measurement result or not. ON is to display, OFF is not to display.
- **0 ADJ (ON/OFF):** OFF is to turn off the function of short correction, while ON is to turn on the function of short correction.
- **0 ADJ:** Execute short correction. In this process, please ensure the test terminals have been correctly shorted. **Only by doing this, unexpected measurement errors could be avoided.**

NOTE:

SPEED: In SLOW2, SLOW1, MED or FAST mode, the measurement result is a 5-digit number.

SAVE: Once SAVE DATA OFF is selected, you must press SAVE DATA ON to terminate or the saved data will be lost.

SHORT: When this key is used to take short correction, the test fixture should be correctly connected. If not, the deducted data will be wrong, and further it will cause result errors. The correct connection is shown as the following figure.

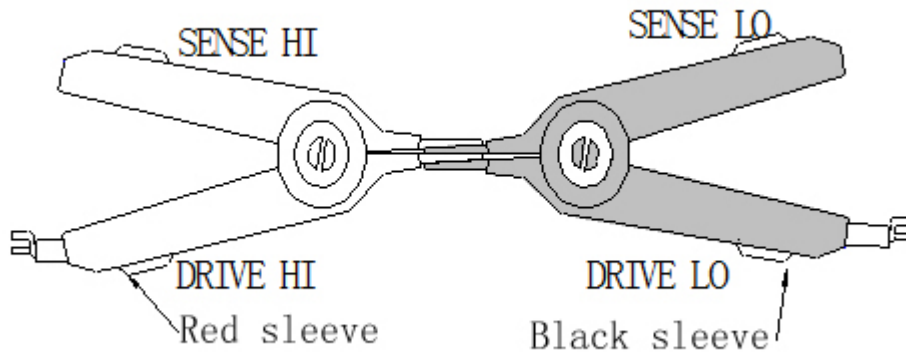

3.2 <COMP DISP>

Touch <MEAS DISP> or press [MEAS] to select the **COMP DISP** soft key to enter into the <COMP DISP> page shown as figure 3-2.

<COMP DISP>		FILE	TOOLS	MEAS DISP
COMP OFF	COMP MODE ABS	HIGH 225.000	LOW 63.0000	COMP DISP
R: 499.76 Ω COMP: HI TOT:0 IN :0 HI :0 LO :0				BIN DISP
U Disk is available				STATICS DISP
11:36:54				
				MORE 1/2

Figure 3-2

The following parameters can be set on this page:

- **FILE**
- **TOOLS**
- **COMP ON/OFF**
- **COMP MODE**
- **NOM (nominal value)**
- **Low limit (%)**

3.2.1 File Manage

- 1) Touch **FILE**, the following soft keys will be displayed:
 - File manage: Touch this soft key to enter into the file manage page.
 - Screen copy: Touch this key to save the current screen page to a U disk. If no U disk is found,

this function will be disabled.

- **Save Data OFF:** Touch this key, this key will turn to <Save Data ON> and each measurement result will be continuously saved to the .CSV file in U disk. Before a U disk is inserted, the save function will be disabled. Press the key again, this key will turn to <Save Data OFF> and the measurement result will not be saved. When switching between ON and OFF once, a new .CSV file will be created in a U disk. The measurement data can be analyzed by opening the file through the computer.
- 2) Refer to 4.2 for more details about **FILE MANAGE**.

3.2.2 Tools

Touch <TOOLS>, the following soft keys will be displayed.

- **DISP (ON/OFF):** ON is to display the measurement result and OFF is not to.
- **BEEP (NG/GD/OFF):** NG: The beeper will sound when the measurement result is not consistent with the setting value. GD: The beep will sound when the measurement result conforms to the setting value. OFF: Turn off the beeper.
- **COUNT (ON/OFF):** ON: Start count; OFF: Stop count.
- **COUNT CLEAR:** Clear the count numbers of TOT, IN, HI and LO and start count from zero.
- **DISP MODE NORMAL:** press the key, **DISP Mode DEV** will be displayed. The value of deviation Δ will be displayed in the main display interface and the display range is -99.9~999.9%. Press the key again and **DISP MODE NORMAL** will be displayed.

NOTE: $\Delta = \{(\text{measured resistance value} - \text{nominal resistance}) / \text{nominal resistance}\} \times 100\%$

3.2.3 COMP (ON/OFF)

COMP (ON/OFF): **ON** indicates the compare function has been turned on. Only when the compare function is in ON mode, count and beep function can be enabled.
OFF is to turn off this function.

3.2.4 Compare Mode and SETTINGS of ABS & Percent Error

You can set the compare mode and concerned values by touching the screen or pressing keyboard. There are two compare modes: ABS and %.

Compare modes:

1) ABS (high and low limits)

In this mode, you can set low and high limits. The instrument will take comparison between the tested values and the set ones so as to judge the DUT is HI or LO or IN. **The set upper limit value should be equal or larger than the lower limit value.**

2) % (percent error)

In this mode, you can set the nominal value and the percent error. If you set the nominal value as 100 and percent as 10, the set value should be $100 \pm 10\%$. The instrument will take comparison between the tested values and the set ones so as to judge the DUT is HI or LO or IN. **The nominal**

value is the base value in bias display mode.

3.3<BIN DISP>

Touch <MEAS DISP> or press [MEAS]. Then select the soft key **BIN DISP** to enter into <BIN DISP> shown as figure 3-3.

<BIN DISP>		FILE	TOOLS	MEAS DISP
BIN ON	BIN BEEP NG	NG COLOR RED	GD COLOR GREEN	COMP DISP
				BIN DISP
				STATIS DISP
				MORE 1/2

Figure 3-3 Bin display

The following parameters can be set on <BIN DISP>.

- **FILE**
 - 1) File Manage: Touch this key to enter into the file manage page.
 - 2) Screen Copy: Touch this key to save the current screen page to an external U disk. If no U disk is found, this function will be disabled.
 - 3) Save Data OFF: Touch this key, this key will turn to <Save Data ON> and each measurement result will be continuously saved to the .CSV file in U disk. Before a U disk is inserted, the save function will be disabled. Press the key again, this key will turn to <Save Data OFF> and the measurement result will not be saved. When switching between ON and OFF once, a new .CSV file will be created in a U disk. The measurement data can be analyzed by opening the file through the computer.
- **TOOLS**
DISP (ON/OFF): ON is to display the result while OFF is not to.
- **BIN**
BIN ON/OFF: ON is to turn on bin compare display while OFF is to turn off.
- **BIN BEEP ON/OFF**
OFF is to turn off the bin beep function.
NG: Bin beep function is ON. When one of the bin comparator results is not consistent with the bin setting, the beep will sound.
GD: Bin beep function is ON. When the bin comparator results are consistent with bin setting, the beep will sound.
- **NG Color**
OFF: When the corresponding bin comparator result is different from the bin setting, there is no display. **GREY**: When the corresponding bin comparator result is different from the bin

setting, the corresponding bin will be displayed in grey; **RED**: When the corresponding bin comparator result is different from the bin setting, the corresponding bin will be displayed in red; **GREEN**: When the corresponding bin comparator result is different from the bin setting, the corresponding bin will be displayed in green.

■ **GD Color**

OFF: When the corresponding bin comparator result conforms to the bin setting, there is no display. **GREY**: When the corresponding bin comparator result conforms to the bin setting, the corresponding bin will be displayed in grey; **RED**: When the corresponding bin comparator result conforms to the bin setting, the corresponding bin will be displayed in red; **GREEN**: When the corresponding bin comparator result conforms to the bin setting, the corresponding bin will be displayed in green.

NOTE: NG is the abbreviation of not good while GD is the abbreviation of good.

3.4 STATIS DISP

Touch the main menu or press [MEAS]. And then touch the soft key **STATIS DISP** to enter into the <STATIS DISP> page shown as figure 3-4.

STATIS DISP		FILE	TOOLS	MEAS DISP
EdgeMode %	NOM 500.360	% 20.0000	Status ON	COMP DISP
\bar{X} 499.75	σ 176.78m	s 176.78m	Cp 99.990	BIN DISP
Cpk 99.990	Hi (num) 0	Lo (num) 0	In (num) 3	STATIS DISP
Max 449.76	MaxIndex 5	Min 449.70	MinIndex 4	
R:4997.76 Ω num: 3 valn: 3 ☺: Statis is started. Trig!				🕒 11:36:54 MORE1/2

Figure 3-4 Statistic display

The function of this page is to count measurement data. It is workable to analyze the average value of results for multiple measurements, the PASS/FAIL rate and some engineering coefficients. Details are as below.

3.4.1 Edge Mode and Settings of Its Relevant Values

Touch this key, two modes is available: ABS (high and low limits) and % (percent error mode).

When ABS is selected, the adjacent two items on the same line will be high and low limits. Touch them to set the values. When % is selected, the two items on the same line will be nominal value and percent. Touch them to set the values.

3.4.2 Status ON/OFF

Status ON/OFF:

- (1) When ON is selected, except the trigger button, no other keys and buttons could be enabled. The instrument makes a statistic at every trigger.
- (2) When OFF is selected, the statistic function will be turned off and other keys and buttons is available.

3.4.3 Parameters of Statistic Analysis

- 1) \bar{x} : Average value. Corresponding formula: $\bar{x} = \frac{\sum x}{n}$
- 2) σ : Population Standard Deviation. Corresponding formula: $\sigma = \sqrt{\frac{\sum x^2 - n\bar{x}^2}{n}}$ ($=\sigma_n$)
- 3) s : Sample Standard Deviation. Corresponding formula: $s = \sqrt{\frac{\sum x^2 - n\bar{x}^2}{n-1}}$ ($=\sigma_{n-1}$)
- 4) C_p : Process Capability Index (Dispersion). Corresponding formula: $C_p = \frac{|Hi - Lo|}{6s}$
- 5) C_pK : Process Capability Index (Deviation). Corresponding formula: $C_pK = \frac{|Hi - Lo| - |Hi + Lo - 2\bar{x}|}{6s}$

NOTE: Explanations for variables in formulas from 1) to 5):

n : The total measurement times that a sample is used to make statistic analysis, which corresponds to the value of TIMES.

x : Measurement results of each sample measurement. The data are saved in the instrument buffer memory.

Hi : Upper limit value, used to be compared, corresponds to the value of UPPER limit.

Lo : Lower limit value, used to be compared, corresponds to the value of LOWER limit.

When $C_p, C_pK > 1.33$, the working capacity is ideal.

When $1.33 \geq C_p, C_pK > 1.00$, the working capacity is qualified.

When $1.00 \geq C_p, C_pK$, the working capacity is insufficient.

- 6) Hi (num): Be used to add up times that the measurement result exceeds the upper limit value.
- 7) Lo (num): Be used to add up times that the measurement result is less than the lower limit value.
- 8) In (num): Be used to add up times that the measurement result passes.
- 9) Max: Be used to display the maximum measurement result among all measurement results.
- 10) MaxIndex: Be used to display the test serial corresponding to the maximum measurement result.
- 11) Min: Be used to display the minimum measurement result among all measurement results.
- 12) MinIndex: Be used to display the test serial corresponding to the minimum measurement result.

3.4.4 TOOLS

- CLEAR: Clear all parameters obtained from last statistic.
- TRIGGER: Trigger the instrument to execute a measurement.

3.4.5 FILE

- 1) File Manage: Touch this key to enter into the file manage page.
- 2) Screen copy: Touch this key to save the current screen page to an external U disk. If no U disk is found, this function will be disabled.
- 3) Save Data OFF: Touch this key, this key will turn to <Save Data ON> and each measurement result will be continuously saved to the .CSV file in U disk. Before a U disk is inserted, the save function will be disabled. Press the key again, this key will turn to <Save Data OFF> and the measurement result will not be saved. When switching between ON and OFF once, a new .CSV file will be created in a U disk. The measurement data can be analyzed by opening the file through the computer.

NOTE 1:

Data storage format successively is R, T, COMP, DEV, DT, BIN1, BIN2, BIN3, COUNT, VCOUNT, STAT, and Time.

The corresponding content of each parameter name is as follows:

R	Resistance measurement result
T	Temperature measurement result
COMP	Comparative result
DEV	Compare deviation result
DT	Delta T test result
BIN1	Resorting result of BIN 1
BIN2	Resorting result of BIN 2
BIN3	Resorting result of BIN 3
COUNT	Count the times

VCOUNT	Valid count times
STAT	System status
Time	Test time

NOTE 2: Before switching from statistics interface to other interface, please firstly set the statistics status as OFF.

3.5<MEAS SETUP>

Touch the main menu. And then touch the soft key **MEAS SETUP** to enter into the MEAS SETUP page shown as figure 3-5.

<MEAS SETUP>		FILE		MEAS SETUP
FUNC R-T	RANGE AUTO		TRIG INT	TC/ Δ t SETUP
TRIG DELAY AUTO	AVERAGE 56		SPEED MED	BIN SETUP
0 ADJ ON	OVC OFF			SYSTEM SETUP
			 11:36:54	MORE 2/2

Figure 3-5 Measurement Setup

On this page, the following parameter can set:

- **FUNC R-T:** Touch this key to select the required parameter.
- **RANGE AUTO:** Touch this key, the following soft keys will be displayed: AUTO (automatically set the resistance range), HOLD (lock the resistance range), \uparrow (increase the range), \downarrow (decrease the range). Touch the corresponding soft key to set the range mode.
- **TRIG INT:** Touch this key, the following soft keys will be displayed in the soft key zone: INT (auto measurement mode), MAN (manual measurement mode), EXT (external trigger mode), BUS (BUS trigger mode).
- **TRIG DELAY:** Touch this key, the following soft keys will be displayed: **AUTO**, **MANUAL**, **INPUT**.
NOTE: The setting of manual measurement delay time is determined by inputting. Range: 0ms—9.99ms. If the delay time is set as 0ms, the detection for wrong measurement cannot be executed. Therefore, it is recommended to set the delay time being more than 1ms.
- **AVERAGE:** Touch this key, a numeric keyboard will pop up. Input the average number ranging from 1 to 255. The larger the average number is set, the better the accuracy will be obtained but the longer time it will cost to display the result.
- **SPEED MED:** This mode is usually applied in 4-terminal measurement. Touch this key, **SLOW1**, **SLOW2**, **FAST** and **MED** will be selectable. In **SLOW1** and **SLOW2** mode, the noise is lower; in **FAST** mode, noise suppression is needed. **FAST** is high speed measurement.

- **0 ADJ:** Touch this key to select **ON** or **OFF**. **ON** is to turn on the short correction function while **OFF** is to turn off.
- **OVC:** Touch this key to select **ON** or **OFF**. **ON** is to turn on the compensation voltage while **OFF** is to turn off.
TH2516B has no OVC function.

3.6<TC/Δt SETUP> (TH2516)

Touch the main menu. And then touch the soft key **TC/Δt SETUP** to enter into the TC/Δt setup page shown as figure 3-6.

<TC/ΔT SETUP>		FILE		MEAS SETUP
FUNC R	TC/Δt OFF	T.SENS Pt		TC/Δt SETUP
t0(°C) 20.0	αt0(ppm) 3390	R1(Ω) 100.00		BIN SETUP
t1(°C) 23.0	k 236.0	V1(v) 0.00		SYSTEM SETUP
T1(°C) 0.0	V2(v) 1.00	T2(°C) 500.0		
			 11:36:54	MORE 2/2

Figure 3-6 TC/Δt setup

3.6.1 Temperature Correction (TC)

Temperature correction (TC): By this function, the resistance tested under the current environment temperature will be converted to a resistance value under the user-set environment temperature. For instance, a resistor is tested as 100Ω under 20°C. If user sets the temperature as 10°C, after correction, the value will be displayed as 96.22Ω. This is realized by formulary conversion.

Formula: $R_t = R_{t0} * \{1 + \alpha_{t0} * (t - t_0)\}$

- R_t** Resistance measured under the current environment temperature
- R_{t0}** Resistance after correction
- t₀** Preset temperature
- t** Current environment temperature
- α_{t0}** Temperature coefficient of the material

For example: A resistor is measured as 100Ω under 20°C (Suppose the temperature coefficient as 3930ppm), the resistance under 10°C will be 96.22Ω.

$$R_{t_0} = \frac{R_t}{1 + \alpha_{t_0} * (t - t_0)} = \frac{100}{1 + (3930 \times 10^{-6}) \times (20 - 10)} = 96.22\Omega$$

NOTE: Before measurement, it is necessary to warm up the instrument and the probe for about half an hour. The temperature sensor should be placed to the DUT as close as possible but cannot contact it. After the displayed result comes to be stable, you can read or record the result.

3.6.2 Temperature conversion (Δt)

Temperature conversion (Δt): Basically, resistors have heat effect. Temperature conversion represents the temperature difference between the resistor and the environment.

Formula:
$$\Delta t = \frac{R2}{R1} (k + t1) - (k + ta)$$

Δt is the temperature increment.

$t1$ is the temperature at the start of resistance measurement.

ta is the environment temperature.

$R1$ is the resistance at the start of contact.

$R2$ is the resistance after the display is stable.

K is the variance ration of the environment temperature coefficient when the conductor is at 0°C.

For example

When $R1$ is 200mΩ, $t1$ is 20°C, $R2$ is 210mΩ, ta is 25°C and k is 235.

$$\Delta t = \frac{R2}{R1} (k + t1) - (k + ta) = \frac{210 \times 10^{-3}}{200 \times 10^{-3}} (235 + 20) - (235 + 25) = 7.75^\circ\text{C}$$

The temperature after the resistance is stable is calculated as the following formula:

$$t_R = ta + \Delta t = 25 + 7.75 = 32.75^\circ\text{C}$$

Where, $k = \frac{1}{at0} - t0 = \frac{1}{3930 \times 10^{-6}} - 20 = 234.5$

NOTE: Conductivity and temperature coefficient of metal and alloy

Metallic material	Metal [%]	Material density ($\times 10^3$) [kg/m ³]	Conductivity	Temperature coefficient (20°C) [ppm]
Annealed copper	Copper>99.9	8.89	1.00 to 1.02	3810 to 3970
Hard-drawn copper	Copper>99.9	8.89	0.96 to 0.98	3370 to 3850
Cadmium copper	Cadmium: 0.7 to 1.2	8.94	0.85 to 0.88	3340 to 3460
Silver copper	Silver: 0.03 to 0.1	8.89	0.96 to 0.98	3930

Chromium copper	Chromium: 0.4 to 0.8	8.89	0.40 to 0.50 0.80 to 0.85	20 30
Anti-corrosion alloy	Nickel: 2.5 to 4.0 Silicon: 0.5 to 1.0	---	0.25 to 0.45	980 to 1770
Soft aluminum	Aluminum>99.5	2.7	0.63 to 0.64	42
Hard-drawn aluminum	Aluminum>99.5	2.7	0.60 to 0.62	40
Aluminum alloy	Silicon: 0.4 to 0.6 Magnesium: 0.4 to 0.5 Aluminum: 99.2 to 98.9	---	0.50 to 0.55	36

NOTE: Calculating the conductivity and the temperature coefficient of the copper wire:

Diameter [mm]	Annealed copper (Conductivity)	Tinning and annealed copper (conductivity)	Hard-drawn copper (Conductivity)
0.01 to 0.26	0.98	0.93	---
0.26 to 0.50	0.993	0.94	0.96
0.50 to 2.00	1.00	0.96	0.96
2.00 to 8.00	1.00	0.97	0.97

Temperature coefficient (α_t) varies with environment temperature and material conductivity. It is supposed that the temperature coefficient of a material at 20°C is α_{20} , its temperature coefficient (α_{ct}) at t°C will be as the following expression:

$$\alpha_{ct} = \frac{1}{\frac{1}{\alpha_{20} \times c} + (t - 20)}$$

3.6.3 Types of Temperature Sensor

There are two temperature input types: Pt and Analog Input.

PT500

Touch the **T.SENS** soft key to select the temperature input type. Select PT and the input type of the temperature is platinum resistor temperature sensor. At this time, standard configuration of "PT500 temperature sensor" should be inserted in the temperature measurement input terminal.

Analog Input

Touch the **T.SENS** soft key to select the temperature input type. AnLG_In is analog input(the input voltage is 0-2V) and the corresponding forma is:

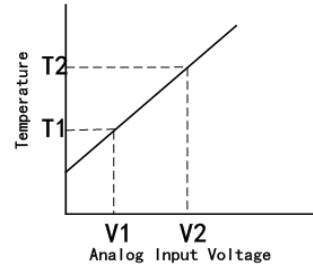

$$\frac{T2 - T1}{V2 - V1} * (\text{Input Voltage}) + \frac{T1V2 - T2V1}{V2 - V1}$$

NOTE: V1 and V2 range from 00.00V to 02.00V while T1 and T2 range from -99.9°C to 999.9°C.

3.6.4 Parameter Setting

- **t0**: Touch this key, the numeric keyboard will pop up and you can input the reference temperature (-10-99.9°C).
- **α_{t0}**: Touch this key, the numeric keyboard will pop up and you can input the reference temperature (-999999-999999).
- **R1**: Touch this key, the numeric keyboard will pop up and input the set resistance value (0-2MΩ).
- **t1**: Touch this key, the numeric keyboard will pop up and input the set temperature value (-10-99.9°C).
- **k**: Touch this key, a numeric keyboard will pop up and you can input the reciprocal of the temperature coefficient (0-9999).
- **V1**: Touch this key, a numeric keyboard will pop up and you can input the set voltage value (0-2V).
- **T1**: Touch this key, a numeric keyboard will pop up and you can input the set temperature value(-100-999.9°C).
- **V2**: Touch this key, a numeric keyboard will pop up and you can input the set voltage value (0-2V).
- **T2**: Touch this key, a numeric keyboard will pop up and you can input the set temperature value (-100-999.9°C).
- **TC/Δt**: Touch this key, **OFF**, **TC** and **Δt** will be displayed in the soft key zone. Touch the corresponding key to choose.
- **T.SENS**: Touch this key, **Pt** and **AnaLG_In** will be displayed in the soft key zone. Touch the corresponding key to choose.

3.6.5 File

- 1) File manage: Touch this key to enter into the file manage page.
- 2) Screen copy: Touch this key to save the screen page to an external U disk. If no U disk is found, the function will be disabled.

3.7<BIN SETUP>

Touch the main menu. And then touch MORE 1/2 to select **BIN SETUP**, and the corresponding Bin Setup page will be displayed as figure 3-7:

BIN SETUP		FILE	TOOLS	MEAS SETUP
BIN NO.	STATE	NOM	%	TC/ Δ t SETUP
0	ON	500.000	10.0000	BIN SETUP
1	ON	490.000	20.0000	SYSTEM SETUP
2	ON	510.000	15.0000	
📶 11:36:54				MORE 1/2

Figure 3-7 Bin Setup

On this page you can set all parameters concerned with the bin comparator. There are 3 groups of parameters (high and low limits, nominal value, %) can be set.

The following parameters can be set on this page:

- **BIN:** Touch 1, 2, 3 below the bin, a **Delete** soft key will be displayed which can be used to clear the high and low limits, nominal value, % of the bin.
- **STATE:** Display the bin state as ON or OFF. When ON is set, the corresponding bin in the display zone will be shown as lighted circle. When OFF is set, the corresponding bin is shown as a horizontal line.
- **TOOLS:** Touch **TOOLS**, the following soft keys will be displayed: MODE, BEEP and CLEAR. Touch **MODE** to select **ABS** (Absolute value error mode) or **%** (percentage error) and correspondingly high and low limits, nominal value, %. Press the touch key of the corresponding bin, a numeric keyboard will pop up and you can set the relevant parameters of the values. There are three bin beep modes: **OFF**, **GD** and **NG**. **CLEAR** can clear the setting parameters of all the three bins.

4) System Setup and File Manage

4.1 System Setup

Entering the system setup page, you can press **[SYSTEM]** or touch **MORE2/2** on any display page to select system setup function as shown in figure 4-1.

<SYSTEM SETUP>		FILE	TOOLS	MEAS SETUP
Touch Tone OFF	Language Chinese	Password OFF		TC/ Δ t SETUP
Bus Mode RS232C	Baud Rate 9600	AC Freq 50Hz		BIN SETUP
Handler VCC INT	LCD Style DEFAULT			SYSTEM SETUP
Time: 13-02-08 09:21:19				
				MORE 2/2

Figure 4-1 System Setup

On this page, the following functions can be set: TouchTone, Language, Password, Bus Mode, Baud Rate, AC Freq, Handler VCC, LCD Style and Time.

4.1.1 Tools

The function is used for system reset and system parameter setting reset.

Steps for reset operation:

Touch **TOOLS**, the following soft keys will be displayed:

- **System Reset**

Touch this key to reset the system, namely, to restart the instrument.

- **Default Setting**

The reset system parameter setting is default. The parameter list is shown as follows:

Parameter	Default value
LCD style	DEFAULT
TouchTone	ON
Language	English
PassWord Mode	OFF
Password	2516
BUS mode	RS232
Baud Rate	9600
Handler Vcc	INT

4.1.2 TouchTone

The function is used to control the touch tone.

Steps for setting the touch tone

Touch **TouchTone**, the following soft keys will be displayed:

- **ON**

Touch this key to turn on the touch tone.

- **OFF**

Touch this key to turn off the touch tone.

You can touch soft keys to set corresponding functions.

4.1.3 Language

The function is used to set the language.

Steps for setting the language

Touch **Language**, the following soft keys will be displayed:

- **English**

Touch this soft key to set the language as English.

- **Chinese**

Touch this soft key to set the language as Chinese.

You can touch soft keys to set corresponding functions.

4.1.4 Password

The function is used to set the password.

Steps for setting the password

Touch **Password**, the following soft keys will be displayed:

- **OFF**

Touch this key to turn off the password protection function. This function would be disabled only when the preset password is correctly input.

- **LOCK SYSTEM**

Touch this key to enable the password function. Please input the password which will be required to be input when opening a file or starting up the instrument.

- **LOCK FILE**

It is necessary to input the password if this function is enabled.

- **MODIFY**

Touch this key to modify the password.

Steps for modify the password:

Touch **MODIFY**, a numeric keyboard will pop up then you should input the original password and press [ENTER] to confirm. Input the new password when the numeric keyboard is shown once

again and press [ENTER] to confirm. Then the numeric keyboard will be displayed for the third time, please input the new password. Press [ENTER] to finish the password modification.

NOTE: The default password is 2516.

4.1.5 Bus Mode

Touch this zone to select the communication interface.

Steps for setting the bus mode

- 1) Touch **Bus Mode**, the following soft keys will be displayed:
 - **RS232C**
 - **USBTMC**
 - **USBVCOM**
- 2) Touch **RS232C** to select the RS232C interface.
- 3) Touch **USBTMC** to select the USBTMC interface. The instrument communicates with PC through the USB interface on the rear panel.
- 4) Touch **USBVCOM** to select the USBVCOM interface. The instrument communicates with PC through the USB interface on the rear panel.

4.1.6 Baud Rate

Touch this key, the following six baud rates is selectable:

- 9600
- 19200
- 28800
- 38400
- 96000
- 115200

4.1.7 AC Freq

TH2516 supplies two power supply frequencies: **50Hz** and **60Hz**. Please select the correct frequency so as to eliminate the influence of the power noise on the instrument.

4.1.8 Handler VCC

Press the Handler VCC, the following six baud rates is selectable:

- EXT
- INT

Press EXT, external power supply is selected.

Press INT, internal power supply is selected.

4.1.9 LCD Style

Press LCD Style, the following six baud rates is selectable:

- DEFAULT
- CLASSIC

Press DEFAULT, default style interface is selected.

Press CLASSIC, classic style interface is selected.

4.1.10 Setting Time and Date

Set the time.

For example: 9 o'clock 21 minute and 19 second a.m. on February 8, 2013 will be shown as 13-02-08 09:21:19.

Operations are as follows: Touch the time zone to be modified, the following items will be displayed.

- ↑↑ (++)

Touch this key, the time will increase rapidly by 5.

- ↑ (+)

Touch this key, the time will increase by 1.

- ↓ (-)

Touch this key, the instrument will decrease by 1.

- ↓↓ (--)

Touch this key, the instrument will decrease rapidly by 5.

- <<

Touch this key, the cursor under the time will move left.

- >>

Touch this key, the cursor under the time will move right.

4.2<File Manage>

TH2516 series can save parameters that are set by user to the internal non-volatile memory in the file format. User can load the file to use these parameters instead of resetting.

This section will introduce the information about the function of Save/Recall.

Notation Explanation:

E: Abbreviation of External, representing external memory, like U disk.

I: Abbreviation of Internal, representing internal memory, like internal Flash of TH2516.

4.2.1 Introduction to Save/Recall

By the function of save/recall, user can save measurement results and configuration information to TH2516 internal Flash or external U disk; meanwhile user can recall data from TH2516 internal

Flash or external U disk.

Introduction to Methods and Applications of Save

The table below shows the applicable save methods and applications:

save method		recall	application
type	file format		
configuration save (internal Flash)	*.STA	Yes	Save the current configuration to internal Flash.
configuration save (external U disk)	*.STA	Yes	Save the current configuration to a U disk.
data save (external U disk)	*.CSV	No	Save measurement results to a U disk.
screen save (external U disk)	*.gif	No	Save the screen information to a U disk.

Table 4-1 Methods and Applications of Save

4.2.2 Structure of File Folder/File in a U Disk

Before saving data to a U disk, you are recommended to save it into a file and folder that have existed in the memory as shown in table 4-2. If you want to save the configuration file into a file folder in PC, you should enter into the folder on the instrument and then take relative file operations.

Folder	Maximum Amount of File	Description
CSV	999	Including measurement result, like *.CSV file.
STA	999	Including configuration data, like *.STA file.
IMAGE	20	Including screen information, like *.gif file.

Table 4-2 Folder in U disk

NOTE: CSV and STA folders might be automatically generated when a U disk is connected.

Structure of Folder/File in a U disk is shown in figure 4-2.

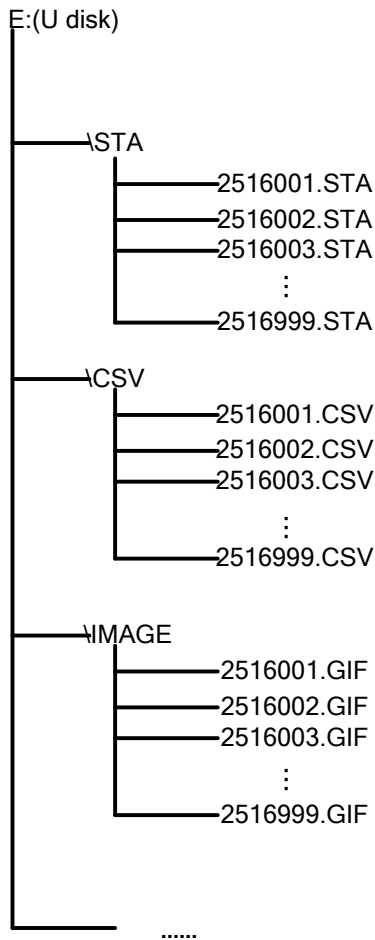

Figure 4-2 file structure in a U disk

When using a U disk on TH2516, you should pay special attention to the following points:

1. Use a U disk with the USB2.0 interface.
2. The U disk file system should be FAT16 or FAT32. FAT16 or FAT32 standard should be used to format the U disk. If the U disk memory exceeds 512M, it is recommended to use FAT32 standard to format the disk.
3. Before a U disk is connected to TH2516, you are recommended to save the data on it and Tonghui will not be liable for the data loss.
4. In order to rapidly save the instrument data to a U disk, it is not recommended to store too many files or folders.

Operation Procedures

Touch **FILE** in any page and select **File Manage** to enter into the internal file page (or directly press the FILE button on the front panel) as shown in below figure.

Touch [Inter File] and [External File] to respectively display files stored in the internal FLASH and the external U disk. Touch [Exit] to exit the file manage page.

INTERNAL FILE		Internal File
1 P. STA	2011/05/30 15:02	External File
2 Q. STA	2011/05/30 15:04	Exit
3		
4		
Page 1		
		 10:19:05

Figure 4-3 External file page



EXTERNAL FILE	E:\	Internal File
 CSV	2011/06/18 17:06	External File
 STA	2011/06/18 17:06	Exit
Page 1		
		 10:19:55

Figure 4-4 External file page

Four files' information will be displayed in the internal file page or the external file page, including file names and time of being saved.

Operations of the internal file and the external file are similar. Take internal file operations as an example to describe the specific procedures of file operations.

Operations on file are as follows:

Touch the file name to be edited (If the file name does not exist in the current page, you can touch [Page 1] and select [Previous Page] and [Next Page] to toggle between file pages, and then select the desired file.), the following items will be displayed.

- **Load**

Touch this key, if the file name that the cursor locates is not empty, [YES] and [NO] will

be displayed in the soft key zone. When [YES] is selected, the instrument will load the setup data in the file; when [NO] is selected, the current operation will be cancelled.

- **Save**
Touch this key, [YES] and [NO] will be displayed in the soft key zone. When [NO] is selected, the current operation of save file will be cancelled; when [YES] is selected, the numerical keyboard will pop up and then you can input the file name and press [ENTER] to finish inputting. Thus the current settings in all pages will be saved to the file. (NOTE: When storing a file, if the inputting file number has already existed, the save operation will overwrite the original file.)
- **Delete**
Touch "Delete", if "YES" is selected, the instrument will delete the file that the cursor locates.
- **Copy to E:**
Touch "Copy to E". The instrument will copy the file the cursor locates or the selected file to a U disk.
- **Select**
Touch "Select", the file the cursor locates will be selected. TH2516 can simultaneously copy several files to a U disk.
Touch "Select" once again, the selected file will be cancelled from selection.

Save Measurement Results

In the "MEAS DISP" page, touch "FILE" and select "Start Save" to save measurement results to a U disk. Touch "Stop Save", the instrument will stop saving measurement results.

Save Screen Information:

Touch "FILE" and select "Screen Save" to store the current screen information to a U disk.

Operations of External File and Folder

Operations of external file are similar to that of internal file.

5) Performance Index

5.1 Measurement Function

5.1.1 Measurement Parameters and Notations

R: Resistance T: Temperature
LPR: Low current mode

5.1.2 Measurement Groups

Five measurement groups are available:

TH2516: R, R-T, T, LPR, LPR-T

TH2516A, TH2516B: R, LPR

5.1.3 Range

Range Mode: AUTO, MANU (HOLD, UP, DOWN)

5.1.4 Trigger

Internal, Manual, External, BUS

Internal: Continuously test a DUT and then output and display the result.

Manual: Press the "TRIGGER" button on the panel, the instrument will test a DUT once and display the result. This mode keeps in waiting mode when it is not used.

External: Test a DUT once and display the result when the instrument receives an external "start up" signal from the footswitch of HANDLER interface on the rear panel.

BUS: The measurement of the instrument will be triggered through the communication interface.

5.1.5 Mode of Test Terminal

4-terminal measurement mode

DRIVE HI: Current-drive high terminal DRIVE LO: Current-drive low terminal

SENSE HI: Voltage-sense high terminal SENSE LO: Voltage-sense low terminal

5.1.6 Resistance Measurement Time

When OVC is OFF, measurement time= 5ms +t1 (50 Hz) / 5ms+t1 (60 Hz) FAST
 20ms+t1 (50 Hz) / 16.6ms+t1 (60 Hz) MED
 110ms+t1 (50 Hz) / 110ms+t1 (60 Hz) SLOW
 450ms +t1 (50 Hz) / 450ms+t1 (60 Hz) SLOW

When OVC is OFF, measurement time= 10 ms + t+t1 (50 Hz) / 10ms + t+t1 (60 Hz) FAST
 40ms + t+t1 (50 Hz) / 33ms + t+t1 (60 Hz) MED
 220ms + 9* t+t1 (50 Hz) / 220 ms + 11* t+t1 (60 Hz) SLOW
 900ms + 39*t+t1 (50 Hz) /900 ms + 47*t+t1 (60 Hz) SLOW

NOTE: t is the measurement waiting time, t1 is the data processing time, approximately is 5ms.
 More detailed information about time parameters, please refer to Chapter 7 "Handler Interface".

5.1.7 Average

Range from 1 to 255, programmable: this value reflects the measurement times from measuring resistance to measuring display.

5.2 Test Signal

5.2.1 Current range

TH2516: Current range: 1 μ A -- 1A

TH2516A: Current range: 10 μ A – 1A

TH2516B: Current range: 100 μ A -- 1A

5.2.2 Output Voltage of Open Circuit

Output voltage of open circuit: 0.7V, 3V, 40mV

5.2.3 Maximum Display Range

Parameter	Measurement Display Range
R	1 $\mu\Omega$ -- 2M Ω
LPR	0.1m Ω —2.1k Ω
T	-99.9 $^{\circ}$ C -- 999.9 $^{\circ}$ C

5.3 Measurement Accuracy

Measurement accuracy includes the basic measurement accuracy under environmental conditions of basic temperature and humidity and temperature correction factor beyond the environmental conditions of basic temperature and humidity.

Checking the measurement accuracy should be taken under the following circumstances:

- a. Warm-up time should be more than 30 minutes.
- b. Correctly short the test cables, turn 0 ADJ to ON and perform short calibration by pressing the touch key or 0 ADJ panel.

The correct short of the test cable is as follows:

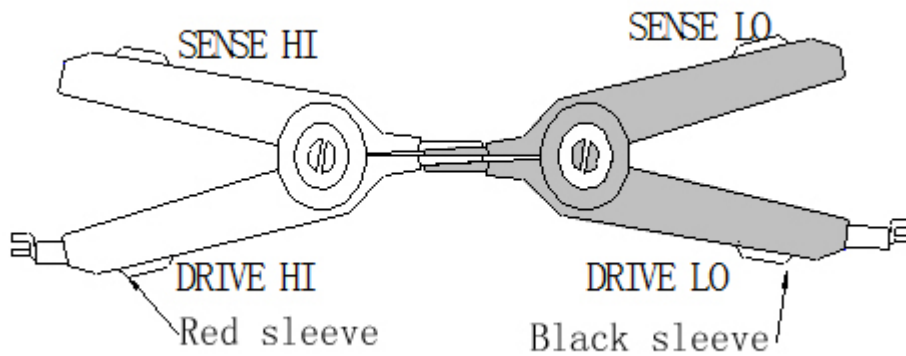

- c. Guarantee the following basic temperature and humidity environmental conditions for basic measurement accuracy.

Temperature range: $23^{\circ}\text{C} \pm 5^{\circ}\text{C}$

Relative humidity: $\leq 80\% \text{RH}$

5.3.1 Basic Accuracy for Resistance Measurement

Basic Measurement Accuracy in one year of TH2516 ($23 \pm 5^{\circ}\text{C}$, $\leq 80\% \text{RH}$)

Range	20mΩ	200mΩ	2Ω	20Ω	200Ω	2kΩ	20kΩ	200kΩ	2MΩ
Current	1A	1A	100mA	10mA	1mA	100μA	100μA	10μA	1μA
OCV	0.7V			3V					
Resolution	1μΩ	10μΩ	100μΩ	1mΩ	10mΩ	100mΩ	1Ω	10Ω	100Ω
Accuracy	0.1%+3	0.05%+2	0.05%+2						0.2%+2
Temperature coefficient	300ppm		100ppm						

Basic Measurement Accuracy in one year of TH2516A (23±5°C, ≤80%RH)

Range	200mΩ	2Ω	20Ω	200Ω	2kΩ	20kΩ	200kΩ
Current	1A	100mA	10mA	1mA	100μA	100μA	10μA
OCV	0.7V		3V				
Resolution	10μΩ	100μΩ	1mΩ	10mΩ	100mΩ	1Ω	10Ω
Accuracy	0.05%+2						
Temperature coefficient	300ppm	100ppm					

Basic Measurement Accuracy in one year of TH2516B (23±5°C, ≤80%RH)

Range	20mΩ	200mΩ	2Ω	20Ω	200Ω	2kΩ	20kΩ
Current	1A	1A	100mA	10mA	1mA	100μA	100μA
OCV	0.7V			3V			
Resolution	1μΩ	10μΩ	100μΩ	1mΩ	10mΩ	100mΩ	1Ω
Accuracy	0.1%+3		0.1%+2				
Temperature coefficient	300ppm		100ppm				

5.3.2 Accuracy for Resistance Tested at Low Current Mode

TH2516, TH2516A, TH2516B Basic Measurement Accuracy in one year (23±5°C, ≤80%RH)

Range	2Ω	20Ω	200Ω	2kΩ
Current	10mA	1mA	100μA	10μA
OCV	40mV			
Resolution	100μΩ	1mΩ	10mΩ	100mΩ
Accuracy	0.2%+5			
Temperature coefficient	200ppm			

Accuracy: Basic Measurement Accuracy in one year (23±5°C, ≤80%RH)

If exceeding the temperature condition, multiply the temperature correction factor K.

5.3.3 Accuracy for Temperature Measurement (Pt500)

TH2516 Basic Measurement Accuracy in one year (23±5°C, ≤80%RH)

Temperature range	-10.0 to 39.9°C	40.0 to 99.9°C
Resolution	0.1°C	0.1°C
Accuracy	±0.45%Rd ±0.8°C	±0.45%Rd ±1.5°C

5.3.4 Accuracy for Temperature Measurement (Analog Input)

TH2516 Basic Measurement Accuracy in one year (23±5°C, ≤80%RH)

Input voltage range	0 to 2V
Temperature range display	-99.9°C to 999.9°C
Resolution	1mV
Accuracy	±1%Rd ± 3mV

$$\text{Accuracy} = 1\% * (T_R - T_{0V}) + 0.3\% * (T_1 - T_{0V})$$

T_{1V} : The temperature measured under input voltage of 1V.

T_{0V} : The temperature measured under input voltage of 0V.

T_R : The current measured temperature.

Note: Rd is the digit reading of measuring instrument; Fs is the full range.

5.3.5 Temperature correction factor

When the instrument is used under the following environmental conditions:

0°C~18°C, ≤80%RH; 28°C~40°C, ≤80%RH

Measurement Accuracy: Multiply the basic measurement accuracy value listed in chapter 5.3.1

-5.3.4 by the temperature correction factor K in the following table.

Temperature(°C)	0 - 5	5 - 18	18 - 28	28 - 35	35 - 40
Temperature correction factor K	4	2	1	2	4

6) Remote Control

6.1 RS232C Connection

RS-232 standard, also called as asynchronous serial communication standard, has already been widely used for data communication between computers, computer and external equipment. RS is the English abbreviation of Recommended Standard; 232, the standard number. This standard is issued by EIA in 1969, which rules to send one bit in a data line every time.

As most serial interfaces, the serial interface of TH2516 is also not strictly based on RS-232 standard but only uses the smallest subset of this standard. The signals are listed in the following table.

Signal	Code	Connector Pin Number
Transmitted Data	TXD	2
Received Data	RXD	3
Signal Ground Common	GND	5

Table 6-1 RS-232 Signal and Pin Connector

The reason is that the use of three lines is much more inexpensive and much simpler than that of five lines or six lines, which is the biggest advantage of using serial interface for communication.

The connection of the instrument with PC is shown in figure 6-1.

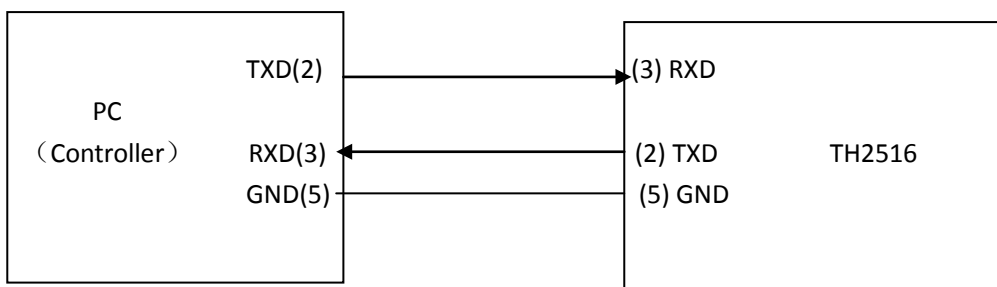

Figure 6-1 Connection of the instrument with PC

Figure 6-1 shows that the serial interface pin definition of this instrument is different from that of 9 pin connector used in the computer. User can purchase the serial interface cable from our company.

RS232 interface characterizes with a baud rate ranging from 9600 to 115200, no parity, 8-bit data bit, 1-bit stop bit.

The instrument commands comply with the SCPI standard. When a command string is

transmitted to the instrument, it is required to send LF (hexadecimal: 0AH) as the terminating character. Each time the maximum receivable number of SPCI command string is 2kB. For result data formats transmitted to a PC from the instrument, see Commands Reference.

6.2 USBTMC Remote Control System

USB (Universal Serial Bus) remote control system controls the instrument through the USB interface. This connection conforms to USBTMC-USB488 and USB2.0 protocols.

6.2.1 System Configuration

Connect USB interfaces on PC and TH2516 through a USB cable.

6.2.2 Install the Driver

When TH2516 is first connected to a PC through a USB cable, the prompt information –Found New Hardware will show on the right bottom of the computer desktop, as is shown below:

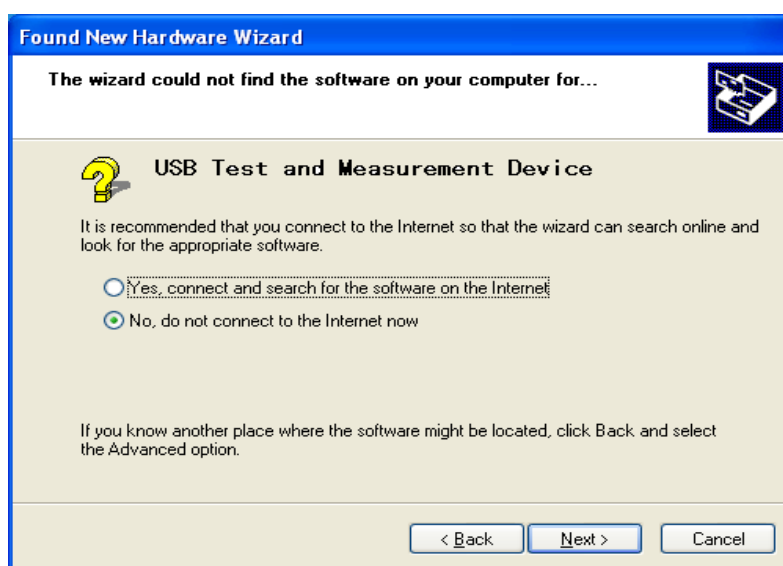

Figure 6-10 Procedure 1 of Installing USB Driver

Click “NEXT”, dialogue 6-11 will pop up. Choose “Install the software automatically (recommended)”.



Figure 6-11 Procedure 2 of Installing USB Driver

When the installation of driver is finished, user can see “usb test and measurement device” in the device manager of PC, as is shown in the following figure.

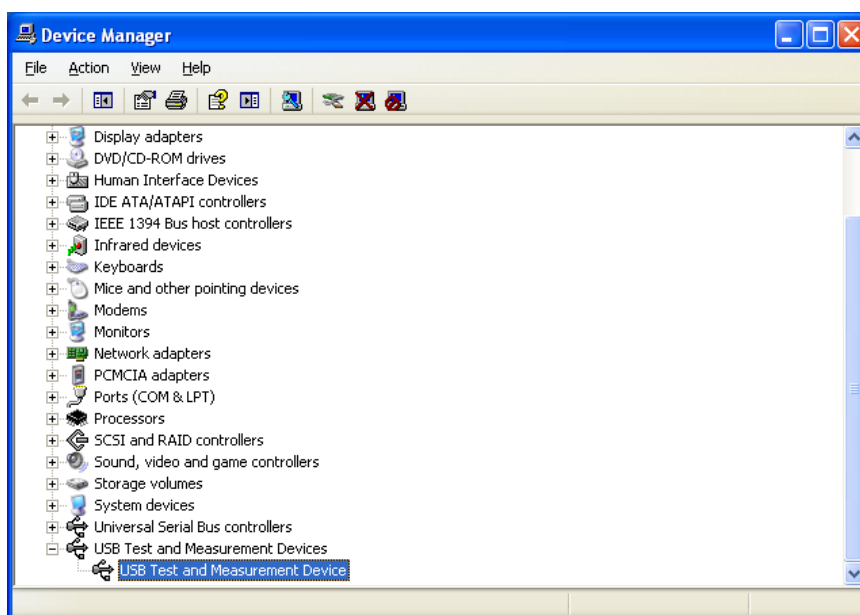

Figure 6-12 USBTMC Display of PC Device Manager

When user is using USBTMC interface, labview software can be used to access the instrument.

6.3 USBVCOM Virtual Serial Port

When “USBVCOM” is selected, the USB interface can be configured as a virtual serial port (VCom).

6.3.1 System Configuration

Connect PC and TH2516 to the USB interface through a USB cable.

6.3.2 Installing Driver

Methods of installing USBVCOM driver are the same with that of installing USBTMC driver. When the installation of driver is finished, user can see “USB VCom Port” in the PC device manager, as is shown in figure 6-13.

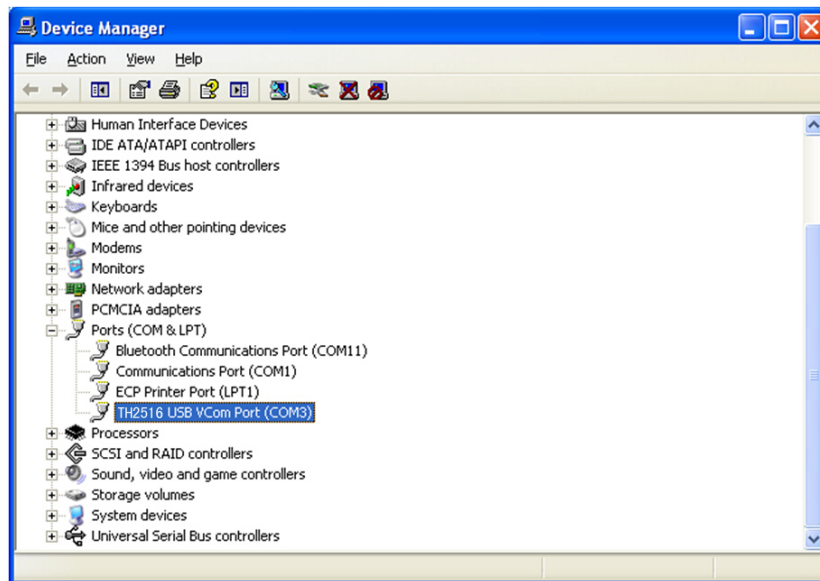

Figure 6-13 VCom Display of PC Device Manager

Now, USB VCom Port acts as a serial port. When PC has no serial port, the communication software based on this serial port can be used as USB virtual serial port.

7) SCIP Command Reference

1. Data Conventions of This Manual

NR1 : integer, for example:123

NR2 : fixed number, for example: 12.3

NR3 : floating number, for example: 12.3E+5

NL : CR character, integer: 10

^END: EOI (end) signal of IEEE-488 bus.

7.1TH2516 Subsystem Commands

- DISPlay ●TRIGger ●COMParator ●APERture ●SYSTEM
- FUNction ●FETCh? ●TEMPerature ●STATistical ●BIN

7.1.1 DISPlay Subsystem Commands

DISPlay subsystem commands are mainly used to set the instrument display page.

The :DISPlay? query returns to the current page.

Command Tree:

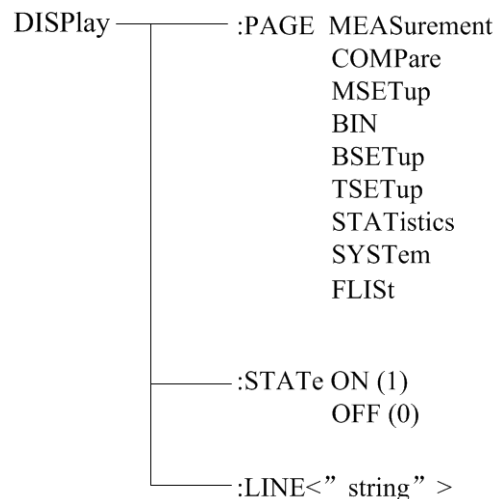

The :PAGE command sets the display page.

The DISPlay:PAGE? query returns to the current page.

Command Syntax: DISPlay:PAGE <page name>

Functions of <page name> are as follows:

- | | |
|-------------|--|
| MEASurement | Set the display page to the basic measurement. |
| COMPare | Set the display page to compare. |
| BIN | Set the display page to bin. |
| MSETup | Set the display page to measurement setup. |
| BSETup | Set the display page to bin setup. |

TSETup	Set the display page to temperature setup. (TH2516)
STATistics	Set the display page to statistics.
SYSTem	Set the display page to system setup.
FLISt	Set the display page to (internal) file list.

For example: WrtCmd("DISP:PAGE MEAS"); Set the display page to basic measurement.

Query syntax: DISPlay:PAGE?

Return format: <page name><NL^END>

Functions of <page name> are as follows:

MEAS	Set the display page to the basic measurement.
COMP	Set the display page to compare.
BIN	Set the display page to bin.
MSET	Set the display page to measurement setup.
BSET	Set the display page to bin setup.
TSET	Set the display page to temperature setup. (TH2516)
STAT	Set the display page to statistics.
SYST	Set the display page to system setup.
FLISt	Set the display page to (internal) file list.

The :STATe command is used to set whether the measurement display page has refreshed the display results.

Command syntax:

DISPlay:STATe	{	ON (0)
	}	OFF (1)

Query syntax: DISPlay:STATe?

Return format: <NR1><NL^END>

<NR1> are as follows:

- 1
- 2

The :LINE command sets the current measurement topic as a substring with up to 20 characters.

The DISPlay:LINE? query returns the current measurement topic. The character string of the measurement topic can be shown in the file list page and be saved as the file name.

Command Syntax: DISPlay:LINE"<string>"

Where:

<string> can be a ASCII character string (up to 20 characters).

For example: WrtCmd("DISP:LINE "Resistor meas"");

Query syntax: DISPlay:LINE?

Return format: <string><NL^END>

7.1.2 FUNcTion Subsystem Commands

FUNcTion subsystem commands are mainly used to set "function", "range", "measurement

pattern”, “self-calibration mode”, etc.. The DISPlay:PAGE? query returns to the current page.

Command Tree:

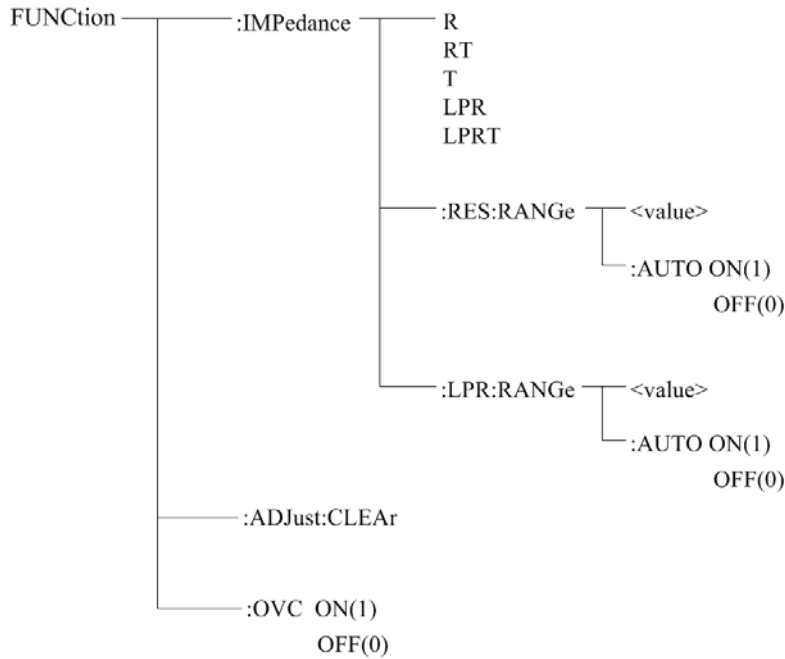

The :IMPedance command sets the “function” parameters.

The FUNcTion:IMPedance? query returns to the current “function” parameters.

Command Syntax: FUNcTion:IMPedance <function>

Details are as follows:

- R Set “function” as R.
- RT Set “function” as R-T. (TH2516)
- T Set “function” as T. (TH2516)
- LPR Set “function” as LPR.
- LPRT Set “function” as LPR-T. (TH2516)

For example: WrtCmd(“FUNC:IMP RT”); Set “function” as R-T .

Query syntax: FUNcTion:IMPedance?

Return Format: <function><NL^END>

If the current “function” is R-T, it will returns to RT.

The :IMPedance:RES:RANGe command sets the instrument range in common resistance measurement pattern.

The FUNcTion:IMPedance:RES:RANGe? query returns to the current range parameters in common resistance measurement pattern.

Command Syntax: FUNcTion:IMPedance:RANGe <value>

Where, <value> can be the impedance of the tested LCR component or the specific range values. Its data format is NR1, NR2, NR3, <value> = 0 to 2E+6.

For example: WrtCmd(“FUNC:IMP:RES:RANG 123”); Set the instrument range in common resistance measurement pattern as 200Ω.

Query syntax: FUNCtion:IMPedance: RES:RANGe?

Return format: <value><NL^END>

Where, <value> can be:

TH2516: 20.000E-3, 200.00E-3, 2000.0E-3, 20.000E+0, 200.00E+0,
2000.0E+0, 20.000E+3, 200.00E+3, 2.0000E+6

TH2516A: 200.00E-3, 2000.0E-3, 20.000E+0, 200.00E+0,
2000.0E+0, 20.000E+3, 200.00E+3

TH2516B: 20.000E-3, 200.00E-3, 2000.0E-3, 20.000E+0, 200.00E+0,
2000.0E+0, 20.000E+3

The :IMPedance:RES:RANGe:AUTO command sets the range auto selection mode in common resistance measurement pattern.

The FUNCtion:IMPedance:RANGe:AUTO? query returns to the current range mode.

Command syntax:

:IMPedance:RES:RANGe:AUTO { ON (1)
OFF (0)

Where,

Character 1 (integer:49) means ON.

Character 0 (integer: 48) means OFF.

For example: WrtCmd("FUNC:IMP:RES:RANG:AUTO ON"); Set the range mode in common resistance measurement pattern as AUTO.

Query syntax: FUNCtion:IMPedance:RES:RANGe:AUTO?

Return format: <NR1><NL^END>

<NR1> = 1 or 0

The:IMPedance:LPR:RANGe command sets the instrument range in resistance tested at low voltage measurement pattern.

The FUNCtion :IMPedance:LPR:RANGe? query returns to the current range parameter in resistance tested at low voltage measurement pattern.

Command syntax: FUNCtion:IMPedance:LPR:RANGe <value>

Where, <value>can be the impedance of the tested LCR component or the specific range values. Its data format is NR1, NR2, NR3, <value> = 0 to 2000.

For example: WrtCmd("FUNC: IMP:LPR:RANG 15"); Set the instrument range in resistance tested at low voltage measurement pattern as 20Ω.

Query syntax: FUNCtion:IMPedance:LPR:RANGe?

Return format: <value><NL^END>

Where, <value> can be:

2000.00E-3, 20.0000E+0, 200.000E+0, 2000.00E+0

The :IMPedance:LPR:RANGe:AUTO command sets the auto selection mode of range in resistance

tested at low voltage measurement pattern.

The FUNCTION :IMPedance:LPR:RANGe:AUTO? query returns to the current range mode.

Command syntax:

:IMPedance:LPR:RANGe:AUTO $\left\{ \begin{array}{l} \text{ON (1)} \\ \text{OFF (0)} \end{array} \right.$

Where:

Character 1 (integer:49) means ON.

Character 0 (integer: 48) means OFF.

For example: WrtCmd("FUNC:IMP:LPR:RANG:AUTO ON"); Set the range in resistance tested at low voltage measurement pattern as AUTO.

Query syntax: FUNCTION:IMPedance:LPR:RANGe:AUTO?

Return format: <NR1><NL^END>

<NR1> = 1 or 0

The :ADJust command is used to execute or clear 0 ADJ.

Clear 0 ADJ data

Command syntax: FUNCTION: ADJust:CLEAr

Execute 0 ADJ operation

Command syntax: FUNCTION: ADJust?

Returned value: <0 or 1><NL^END>

0: it indicates that the 0CAJ has completed successfully and open 0 ADJ after the completion.

1: it indicates that the measured value of resistance exceeds 400 dgt, namely operation failed.

The :OVC command sets the instrument offset voltage compensation state.

The :OVC? Query returns to the current setstate.(TH2516/TH52516A)

Command syntax:

:OVC $\left\{ \begin{array}{l} \text{ON (1)} \\ \text{OFF (0)} \end{array} \right.$

Where,

Character 1 (integer:49) means ON.

Character 0 (integer: 48) means OFF.

For example: WrtCmd("FUNCTION:OVC ON"); Set the instrument offset voltage compensation state as "ON".

Query syntax: FUNCTION: FUNCTION:OVC?

Return format: <NR1><NL^END>

<NR1> = 1 or 0

1: the offset voltage compensation state is "ON".

0: the offset voltage compensation state is "OFF".

7.1.3 APERTure Subsystem Commands

The APERTure subsystem commands are mainly used to set the measurement speed and the average times used in measurement.

The APERTure? query returns to the current measurement speed and average times used in measurement.

Command Tree:

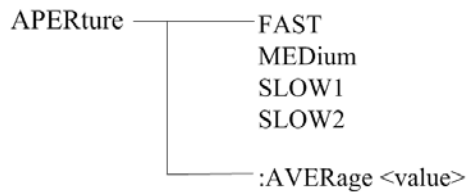

The :APERTure command sets the instrument measurement speed.

The :APERTure? query returns to the current measurement speed.

Command syntax:

Command syntax: APER <FAST, MEDium, SLOW1 or SLOW2>

For example: WrtCmd("APERTure SLOW1"); Set the instrument self-calibration mode as SLOW.

Query syntax: APERTure?

Return format: <FAST, MEDium, SLOW1 or SLOW2> <NL^END>

The :APERTure:AVERage command sets the instrument average times used in measurement.

The :APERTure:AVERage? query returns to the current average times.

Command syntax:

Command syntax: APER:AVERage <value>

Where, <value> = 1 to 255

For example: WrtCmd("APERTure:AVER 10"); Set nstrument average times used in measurement as 10.

Query syntax: APERTure:AVERTure?

Return format: < NR1> <NL^END>

7.1.4 TRIGger Subsystem Commands

The TRIGger subsystem commands set the instrument trigger source and the delay time after triggering, and triggers instrument measurement.

Command Tree:

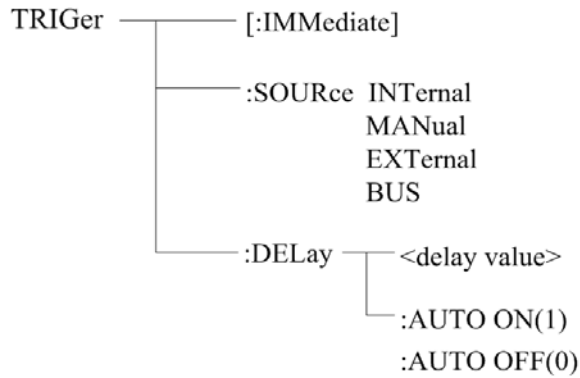

The :IMMEDIATE command triggers a measurement.

Command syntax: TRIGGER[:IMMEDIATE]

For example: WrtCmd("TRIG");

The :SOURCE command sets the mode of trigger source.

The :SOURCE? query returns to the current mode of trigger source.

Command syntax:

TRIGGER:SOURCE <INTERNAL, MANUAL, EXTERNAL or BUS>

Where,

- INTERNAL Be automatically triggered by the instrument and be the default setting of the instrument.
- MANUAL Be triggered by pressing the TRIGGER button on the panel.
- EXTERNAL Be triggered by the HANDLER interface.
- BUS Be triggered by the RS232 interface or the GPIB interface.

For example: WrtCmd("TRIG:SOUR BUS");

Query syntax: TRIGGER:SOURCE?

Return format: <INTERNAL, MANUAL, EXTERNAL or BUS> <NL^END>

The :DELAY command sets the instrument measurement delay time after triggering.

The TRIGGER:DELAY? query returns to the current delay time.

Command syntax:

TRIGGER:DELAY <delay value>

Where, <delay value> = 0 to 9.999 [in seconds]

For example: WrtCmd("TRIG:DEL 0.5"); Set the delay time as 0.5S.

Query syntax: TRIGGER:DELAY?

Return format: <NR2><NL^END>

The :DELAY:AUTO command sets the instrument measurement delay mode after triggering.

The :DELAY:AUTO? query returns to the current delay mode status.

Command syntax:

TRIGGER:DELAY:AUTO ON(1)
OFF(0)

Where, ON Set the measurement delay mode as automatic "ON"

OFF Set the measurement delay mode as automatic "OFF"

For example: WrtCmd("TRIG:DEL:AUTO ON"); Set the delay mode as automatic "ON".

Query syntax: TRIG:DEL:AUTO?

Return format: <NR1><NL^END>

<NR1> = 1 or 0

1: the measurement delay mode is automatic "ON".

0: the measurement delay mode is automatic "OFF".

7.1.5 FETCH? Subsystem Commands

The FETCH? Subsystem commands are used to get the last measurement result and the setup of the mode.

Command Tree:

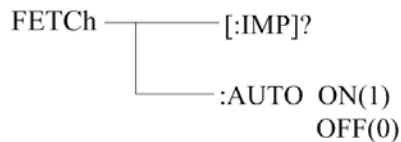

The [:IMP]? query returns TH2516's last measurement result to its output buffer.

Query syntax: FETCH[:IMP]?

The data got from the commands can be divided into three types according to different functions and display page.

1. On the measurement display page, compare display interface, bin display page and statistical interface and the measurement function is one-parameter mode (functions are R, T, LPR):

Data format: <primary parameter>, <system status>;

<primary parameter>= the measured value of the current parameter and the format is NR3 (when the temperature conversion function is enabled and on the measurement display interface, the primary parameter is the temperature increment ΔT), when existing outrange or measurement error, the returned value is "+9.90000E+37".

System status: -1 No data in the buffer zone.
0 Ordinary measurement data.
+1 Measurement status error.

2. On the measurement display page, compare display interface, bin display page and statistical interface and the measurement function is two-parameter mode (functions are R-T, LPR-T):

Data format: <primary parameter>, <secondary parameter>, <system status>;

<primary parameter>= the measurement of the current primary parameter and the format is NR3 (when the temperature conversion function is enabled and on the measurement display interface, the primary parameter is the temperature increment ΔT), when existing outrange or measurement error, the returned value is "+9.90000E+37".

<secondary parameter>= the measurement of the current secondary parameter and the format is NR3, when existing outrange or measurement error, the returned value is "+9.90000E+37".

The system status is the same as above.

3. There is no return value for other display page.

The FETCH:AUTO command sets the automatic mode switch to send each measurement result to its output buffer.

Command syntax: FETCH:AUTO ON(1)
OFF(0)

For example: WrtCmd("FETC:AUTO ON"); namely opening the automatic sending mode of each measurement result.

7.1.6 TEMPerature Subsystem Commands (TH2516)

TEMPerature subsystem commands set the instrument trigger source and the delay time after triggering, and triggers instrument measurement.

Command Tree:

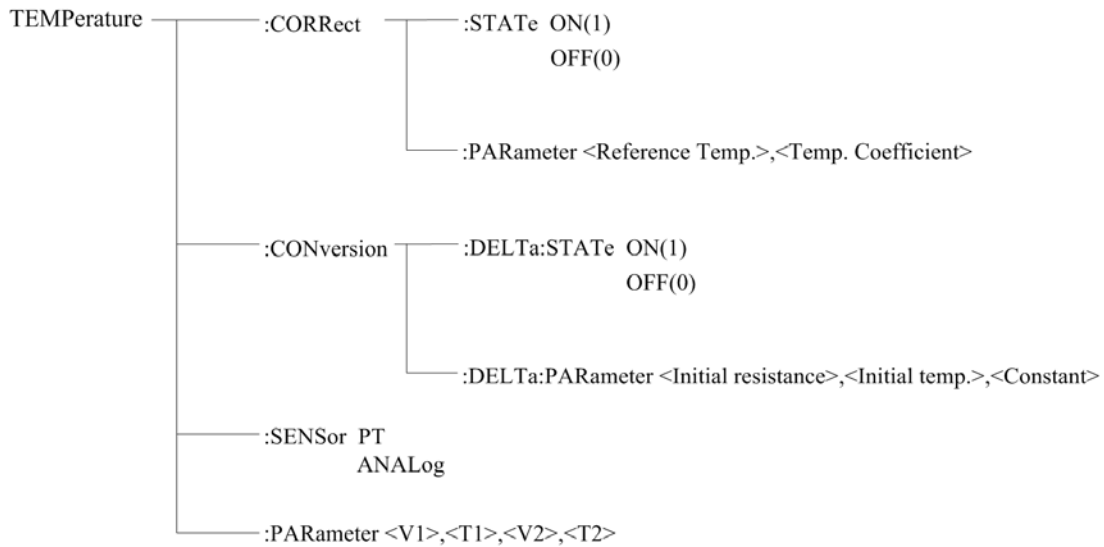

The :TEMPerature:CORRect:STATe command sets "ON" and "OFF" of the instrument temperature correction function.

The :TEMPerature:CORRect:STATe? query returns to the current state of the temperature correction function.

Command syntax:

:TEMPerature:CORRect:STATe <ON(1) or OFF(0)>

For example: WrtCmd(":TEMPerature:CORRect:STATe ON"); Set the instrument temperature correction function as "ON".

NOTE: Turning the temperature correction function on will stop the temperature conversion function!

Query Syntax: :TEMPerature:CORRect:STATe?

Return format: <NR1><NL^END>

<NR1> = 1 or 0

1: the instrument temperature correction function is "ON".

0: the instrument temperature correction function is "OFF".

The :TEMPerature:CORRect:PARAmeter command sets the "reference temperature" and "temperature coefficient" of the instrument temperature correction function.

The :TEMPerature:CORRect:PARAmeter? query returns to the current "reference temperature" and "temperature coefficient".

Command syntax:

:TEMPerature:CORRect:PARAmeter<Reference Temp.>,<Temp. Coefficient>

Where, <Reference Temp.> = -10.0 to 99.9(NR2) means "reference temperature", unit: °C

<Temp. Coefficient> = -99999 to 99999(NR1) means "temperature coefficient", unit: ppm/°C

For example: WrtCmd(":TEMP:CORR:PAR 25,3390"); Set the instrument "reference temperature" and "temperature coefficient" as 25 °C and 3390 ppm/°C respectively.

Query Syntax: :TEMPerature:CORRect:PARAmeter?

Return format: <Reference Temp.>,<Temp. Coefficient><NL^END>

Where, the format and unit of <Reference Temp.>,<Temp. Coefficient> are the same as above.

The :TEMPerature:CONVersion:DELTA:STATe command sets "ON" and "OFF" of the instrument temperature conversion function.

The :TEMPerature:CONVersion:STATe? query returns to the current state of the temperature conversion function.

Command syntax:

:TEMPerature: CONVersion: DELTA:STATe <ON(1) or OFF(0)>

For example: WrtCmd(":TEMPerature:Conversion: :DELTA:STATe ON"); Set the instrument temperature conversion function as "ON".

NOTE: Turning the temperature conversion function on will stop the temperature correction function!

Query Syntax: :TEMPerature:CONVersion:DELTA:STATe?

Return format: <NR1><NL^END>

<NR1> = 1 or 0

1: the temperature conversion function of the instrument is "ON".

0: the temperature conversion function of the instrument is "OFF".

The :TEMPerature:CONVersion:DELTA:PARAmeter command sets the "initial resistance" , "initial temperature" and "constant k" of the instrument temperature conversion function.

The :TEMPerature:CONVersion:DELTA:PARAmeter? query returns to the current "initial

resistance", "initial temperature" and "constant k".

Command syntax:

```
:TEMPerature:CONVersion:DELTA:PARAmeter<Initial resistance>,<Initial temperature>,<Constant>
```

Where, < Initial resistance > = 0 to 110.000E+6(NR3) means "initial resistance", unit: Ω
 < Initial temperature > = -10.0 to 99.9(NR2) means "initial temperature", unit: $^{\circ}\text{C}$
 < Constant > = -999.9 to 999.9(NR2) means "constant k", unit: $^{\circ}\text{C}$

For example: WrtCmd(":TEMP:CON:DEL:PAR 100,20,235"); Set the instrument "initial resistance", "initial temperature" and "constant k" as 100 Ω , 20 $^{\circ}\text{C}$ and 235 $^{\circ}\text{C}$ respectively.

Query Syntax: :TEMPerature:CORRect:STATe:PARAmeter?

Return format: <Initial resistance>,<Initial temperature>,<Constant><NL^END>

Where, the format and unit of <Initial resistance>,<Initial temperature>,<Constant> are the same as above.

The :TEMPerature:SENSor command sets the input mode selection of the instrument temperature sensor.

The :TEMPerature:SENSor? query returns to the current input mode of the temperature sensor.

Command syntax:

```
:TEMPerature:SENSor <PT or ANALog>
```

Where, PT : Using PT500 as the input signal of the temperature sensor

ANALog: Using analog voltage signal as the input signal of the temperature sensor

Query Syntax: :TEMPerature:SENSor?

Return format: < PT or ANAL ><NL^END>

The :TEMPerature:PARAmeter command sets the parameter setting when using analog voltage signal as the input signal of the temperature sensor.

The :TEMPerature:PARAmeter? query returns to the current parameter setting.

Query Syntax:

```
:TEMPerature:PARAmeter <V1>,<T1>,<V2>,<T2>
```

Where, <V1> = 0 to 2.00 (NR2) means "reference voltage1", unit: V
 <T1> = -99.9 to 999.9 (NR2) means "reference temperature1", unit: $^{\circ}\text{C}$
 <V2> = 0 to 2.00 (NR2) means "reference voltage2", unit: V
 <T2> = -99.9 to 999.9 (NR2) means "reference temperature2", unit: $^{\circ}\text{C}$

For example: WrtCmd(":TEMP: PAR 0,0,1,500"); Set the "reference voltage1", "reference temperature1", "reference voltage2" and "reference temperature2" of the instrument as 0V, 0 $^{\circ}\text{C}$, 1V and 500 $^{\circ}\text{C}$ respectively.

Query Syntax: :TEMPerature:PARAmeter?

Return format: the format and unit of <V1>,<T1>,<V2>,<T2><NL^END> are the same as above.

7.1.7 COMParator Subsystem Commands

COMParator subsystem commands are used to set the compare function of the instrument, including the setup of comparator switch, beeper mode, limit mode and other compare parameters.

Command Tree:

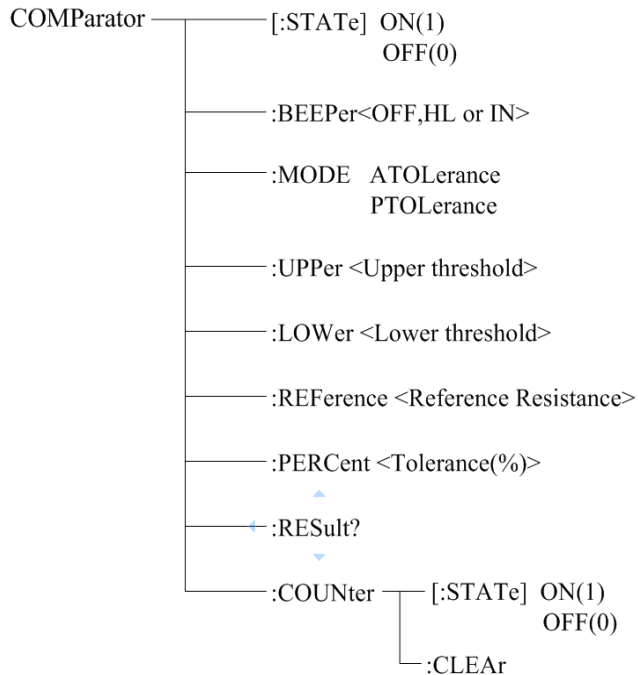

The :COMParator[:STATe] command sets the state of instrument comparator function.

The :COMParator[:STATe]? query returns to the current comparator state.

Command syntax:

```
:COMParator[:STATe] <ON(1) or OFF(0)>
```

For example, WrtCmd(":COMP:STAT ON"); Set the comparator function of the instrument as "ON".

Query Syntax: :COMParator:STATe?

Return format: <NR1><NL^END>

<NR1> = 1 or 0

1: the current comparator function of the instrument is "ON"

0: the current comparator function of the instrument is "OFF"

The :COMParator:BEEPer command sets the comparator beeper mode of the instrument.

The :COMParator:BEEPer? query returns to the current beeper mode.

Command syntax:

```
:COMParator:BEEPer <OFF, HL or IN>
```

Where, OFF: the comparator beeper function is "OFF"

HL : it beeps when the comparative result is not qualified

IN : it beeps when the comparative result is qualified

For example, WrtCmd(":COMP:BEEP IN"); Set the comparator beeper mode as IN.

Query Syntax: :COMParator:BEEPer?

Return format: <OFF, HL or IN><NL^END>

The :COMParator:MODE command sets the comparator limit mode of the instrument.

The :COMParator:MODE? query returns to the current limit mode.

Command syntax:

COMParator:MODE < ATOLerance or PTOLerance >

Where, ATOLerance: set the limit mode of the instrument as absolute tolerance mode

PTOLerance: set the limit mode of the instrument as proportional tolerance mode

For example, WrtCmd("COMP:MODE ATOL"); Set the limit mode of the instrument as absolute tolerance mode.

Query Syntax: COMParator:MODE?

Return format: <ATOL or PTOL><NL^END>

The :COMParator:UPPer command sets the upper threshold of the instrument comparator function.

The :COMParator:UPPer? query returns to the current upper threshold.

Command syntax:

COMParator:UPPer < Upper threshold >

Where,

< Upper threshold > = 0 to 2.2E+6 (NR3) the upper threshold of the
comparator function unit: "Ω"

For example, WrtCmd("COMP:UPP 2000"); Set the the upper threshold of the instrument comparator function as 2000Ω.

NOTE: The upper threshold must be greater than or equal to the lower threshold.

Query Syntax: COMParator:UPPer?

Return format: the format and unit of < Upper threshold ><NL^END> are the same as above.

The :COMParator:LOWer command sets the lower threshold of the instrument comparator function.

The :COMParator: LOWer? query returns to the current lower threshold.

Command syntax:

COMParator: LOWer< Lower threshold >

Where,

< Lower threshold > = 0 to 2.2E+6 (NR3) the lower threshold of the
comparator function unit: "Ω"

For example: WrtCmd("COMP:LOW 1800"); Set the the lower threshold of the instrument comparator function as 1800Ω.

NOTE: The lower threshold must be less than or equal to the upper threshold.

Query Syntax: COMParator: LOWER?

Return format: the format and unit of < Lower threshold ><NL^END> are the same as above.

The :COMParator:REFeRence command sets the reference resistance of the instrument comparator function.

The :COMParator:REFeRence? query returns to the current reference resistance.

Command syntax:

COMParator: REFeRence<Reference Resistance>

Where,

< Reference Resistance > = 0 to 2.2E+6 (NR3) the reference resistance of the comparator function unit: "Ω"

For example: WrtCmd("COMP:REF 20E+3"); Set the reference resistance of the instrument comparator function as 20kΩ.

Query Syntax: COMParator: REFeRence?

Return format: the format and unit of < Reference Resistance ><NL^END> are the same as above.

The :COMParator:PERCent command sets the tolerance of the instrument comparator function.

The :COMParator:PERCent? query returns to the current tolerance.

Command syntax:

COMParator:PERCent<Tolerance(%)>

Where, < Tolerance(%)> = 0 to 99.999 (NR2) the tolerance of the comparator function unit: "%"

For example: WrtCmd("COMP:PERC 10"); Set the tolerance of the instrument comparator function as 10%.

Query Syntax: COMParator: PERCent?

Return format: the format and unit of < Tolerance(%)><NL^END> are the same as above.

The :COMParator:RESult command queries the last comparator result of the instrument.

Query Syntax: COMParator: RESult?

Return format: < HI, IN, LO, OFF or ERR> <NL^END>

Where,

HI: it indicates that the measurement result is greater than the upper boundary of the comparator

IN: it indicates that the measurement result is between the upper and lower boundary of the comparator

LO: it indicates that the measurement result is less than the lower boundary of the instrument

OFF: it indicates that the comparator function is "OFF"

ERR: it indicates that the comparator function is "ON", but there exists the measurement error.

The `:COMParator: COUNter:STATe` command sets the counter state of instrument comparator interface.

The `:COMParator: COUNter:STATe?` query returns to the current counter state.

Command syntax:

```
:COMParator: COUNter :STATe <ON(1) or OFF(0)>
```

For example, `WrtCmd(":COMP:COUN: STAT ON");` Set the counter function of the instrument comparator interface as "ON".

Query Syntax: `:COMParator:COUNter: STATe?`

Return format: `<NR1><NL^END>`

`<NR1> = 1 or 0`

1: the current counter function of the instrument comparator interface is "ON"

0: the current counter function of the instrument comparator interface is "OFF"

The `:COMParator:COUNter:CLEAR` command is used to clear the counter value of the instrument comparator interface.

7.1.8 BIN Subsystem Commands

BIN subsystem commands sets the bin comparator function of the instrument, including bin status switch, beeper mode, limit mode, enable mask and other bin parameters.

Command Tree:

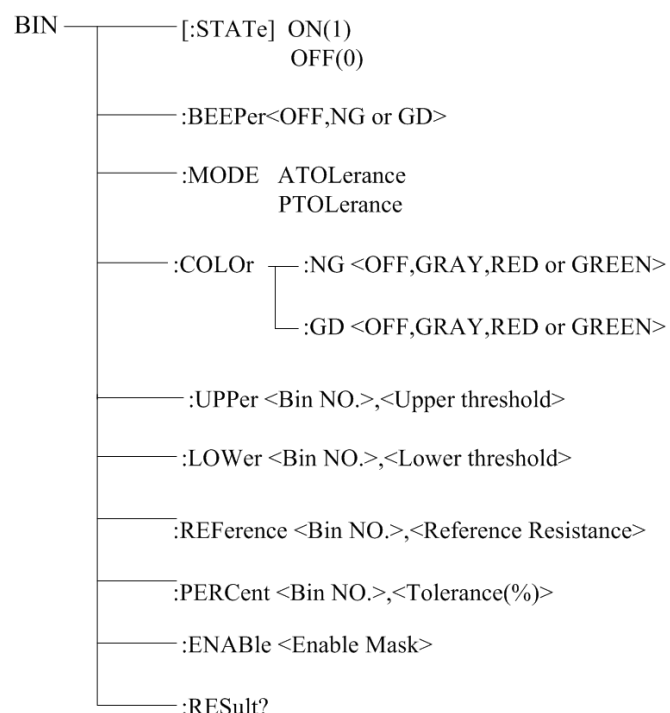

The `:BIN[:STATe]` command sets the state of the instrument comparator.

The `:BIN[:STATe]?` query returns to the current state of the bin comparator.

Command syntax:

```
:BIN[:STATe] <ON(1) or OFF(0)>
```

For example: `WrtCmd(":BIN:STAT ON");` Set the bin comparator function as "ON".

Query Syntax: :BIN:STATE?

Return format: <NR1><NL^END>

<NR1> = 1 or 0

1: the current bin comparator function of the instrument is "ON"

0: the current bin comparator function of the instrument is "OFF"

The :BIN:BEEPer command sets the beeper mode of the instrument bin comparator.

The :BIN:BEEPer? query returns to the current bin beeper mode.

Command syntax:

:BIN:BEEPer <OFF, NG or GD>

Where, OFF: the bin beeper is "OFF"

NG : it beeps when one or more bin comparator results are not qualified

GD : it beeps when all the bin comparator results are qualified

For example: WrtCmd(":BIN:BEEP GD"); Set the comparator beeper mode as GD.

Query Syntax: BIN:BEEPer?

Return format: <OFF, NG or GD><NL^END>

The :BIN:MODE command sets the limit mode of the instrument bin comparator function.

The :BIN:MODE? query returns to the current limit mode.

Command syntax:

BIN:MODE < ATOLerance or PTOLerance >

Where, ATOLerance: set the bin limit mode as absolute tolerance mode

PTOLerance: set the bin limit mode as proportional tolerance mode

For example: WrtCmd("BIN:MODE ATOL"); Set the bin limit mode as absolute tolerance mode.

Query Syntax: BIN:MODE?

Return format: <ATOL or PTOL><NL^END>

The :BIN:COLOR:NG command sets the color of the display mark when the bin comparator result is "NG".

The :BIN:COLOR:NG? query returns to the color of the display mark when the bin comparator result is "NG".

Command syntax:

BIN:COLOR:NG <OFF, GRAY, RED or GREEN>

Where,

OFF: when the bin comparator result is "NG", no result mark will be displayed

GRAY: when the bin comparator result is "NG", set the color of the result mark as GRAY

RED: when the bin comparator result is "NG", set the color of the result mark as RED

GREEN: when the bin comparator result is "NG", set the color of the result mark as GREEN

For example: WrtCmd("BIN:COLOr:NG GRAY"); Set the color of the result mark as GRAY when the bin comparator result is "NG".

Query Syntax: BIN:COLOr:NG?

Return format: <OFF, GRAY, RED or GREEN><NL^END>

The :BIN:COLOr:GD command sets the color of the display mark when the bin comparator result is "GD".

The :BIN:COLOr:GD? query returns to the color of the display mark when the bin comparator result is "GD".

Command syntax:

BIN:COLOr:GD <OFF, GRAY, RED or GREEN>

Where,

OFF: when the bin comparator result is "GD", no result mark will be displayed

GRAY: when the bin comparator result is "GD", set the color of the result mark as GRAY

RED: when the bin comparator result is "GD", set the color of the result mark as RED

GREEN: when the bin comparator result is "GD", set the color of the result mark as GREEN

For example: WrtCmd("BIN:COLOr:GD RED"); Set the color of the result mark as RED when the bin comparator result is "GD".

Query Syntax: BIN:COLOr:GD?

Return format: <OFF, GRAY, RED or GREEN><NL^END>

The :BIN:UPPer command sets the upper threshold of the instrument specific bin.

The :BIN:UPPer? query returns to the upper threshold of the specific bin.

Command syntax:

BIN:UPPer <Bin NO.>,< Upper threshold >

Where, <Bin NO.> = 1 to 3(NR1) specified bin no., namely specific bin

< Upper threshold > = 0 to 2.2E+6 (NR3) the upper threshold of the specific bin
unit: "Ω"

For example: WrtCmd("BIN:UPP 1,2000"); Set the upper threshold of bin 1 as 2000Ω.

NOTE: The upper threshold of the same bin should be greater than or equal to the lower threshold!

Query Syntax: BIN:UPPer?<Bin NO.>

Return format: the format and unit of < Upper threshold ><NL^END> are the same as above.

Note: If the upper threshold does not exist, the returned value is "+9.90000E+37"

The : BIN:LOWer command sets the lower threshold of the instrument specific bin.

The : BIN:LOWer? query returns to the lower threshold of the specific bin.

Command syntax:

BIN: LOWer <Bin NO.>,< Lower threshold >

Where, <Bin NO.> = 1 to 3(NR1) specified bin no., namely specific bin

< Lower threshold > = 0 to 2.2E+6 (NR3) the lower threshold of the specific bin
unit: "Ω"

For example: WrtCmd("BIN:LOW 1,1800"); Set the lower threshold of bin 1 as 1800Ω.

NOTE: The lower threshold of the same bin should be less than or equal to the upper threshold!

Query Syntax: BIN:LOWer?<Bin NO.>

Return format: the format and unit of < Lower threshold ><NL^END> are the same as above.

Note: If the lower threshold does not exist, the returned value is "+9.90000E+37"

The : BIN:REFErence command sets the reference resistance of the instrument specific bin.

The : BIN:REFErence? query returns to the current reference resistance of the specific bin.

Command syntax:

BIN: REFErence <Bin NO.>,<Reference Resistance>

Where,

<Bin NO.> = 1 to 3(NR1) specified bin no., namely specific bin

< Reference Resistance > = 0 to 2.2E+6 (NR3) the reference resistance of the
specific bin unit: "Ω"

For example: WrtCmd("BIN:REF 1,20E+3"); Set the reference resistance of bin 1 as 20kΩ.

Query Syntax: BIN: REFErence?<Bin NO.>

Return format: the format and unit of < Reference Resistance ><NL^END> are the same as above.

Note: If the reference resistance does not exist, the returned value is "+9.90000E+37"

The : BIN:PERCEnt command sets the tolerance of the instrument specific bin.

The : BIN:PERCEnt? query returns to the current tolerance of the specific bin.

Command syntax:

BIN:PERCEnt <Bin NO.>,<Tolerance(%)>

Where,

<Bin NO.> = 1 to 3(NR1) specified bin no., namely specific bin

< Tolerance(%)> = 0 to 99.999 (NR2) the tolerance of the specific bin
unit: "%"

For example: WrtCmd("BIN:PERC 1,10"); Set the tolerance of bin 1 as 10%.

Query Syntax: BIN: PERCEnt?<Bin NO.>

Return format: the format and unit of < Tolerance(%)><NL^END> are the same as above.

Note: If the tolerance does not exist, the returned value is "+9.90000E+37"

The : BIN:ENABle command sets the enable mask of the bin function.

The : BIN:ENABle? query returns to the current enable number of the bin function.

Command syntax:

BIN: ENABle <Enable Mask>

Where,

<Enable Mask> = 0 to 7(NR1) enable mask (decimal system)

Transfer some bit to 1, namely hold the corresponding bin enable

Bit No.	2	1	0
BIN NO.	BIN3	BIN2	BIN1

For example: WrtCmd("BIN:ENAB 6"); Set the enable mask from BIN2 to BIN3.

Query Syntax: BIN:ENABle?

Return format: the format and unit of < Enable Mask ><NL^END> are the same as above.

The :BIN:RESult command queries the last bin comparator result of the instrument.

Query Syntax: BIN:RESult?

Return format: < NR1> <NL^END>

Where,

< NR1> = 0 to 7

When the judging result of some bin is "GD", transfer the corresponding bit to 1

Bin Number	2	1	0
BIN NO.	BIN3	BIN2	BIN1

For example: when < NR1> = 4, only the judging result of BIN3 is "GD'.

7.1.9 STATistics Subsystem Commands

Statistics subsystem commands are used to set the statistics function of the instrument, including statistics state switch, statistics limit, limit mode and statistics data clear.

Command Tree:

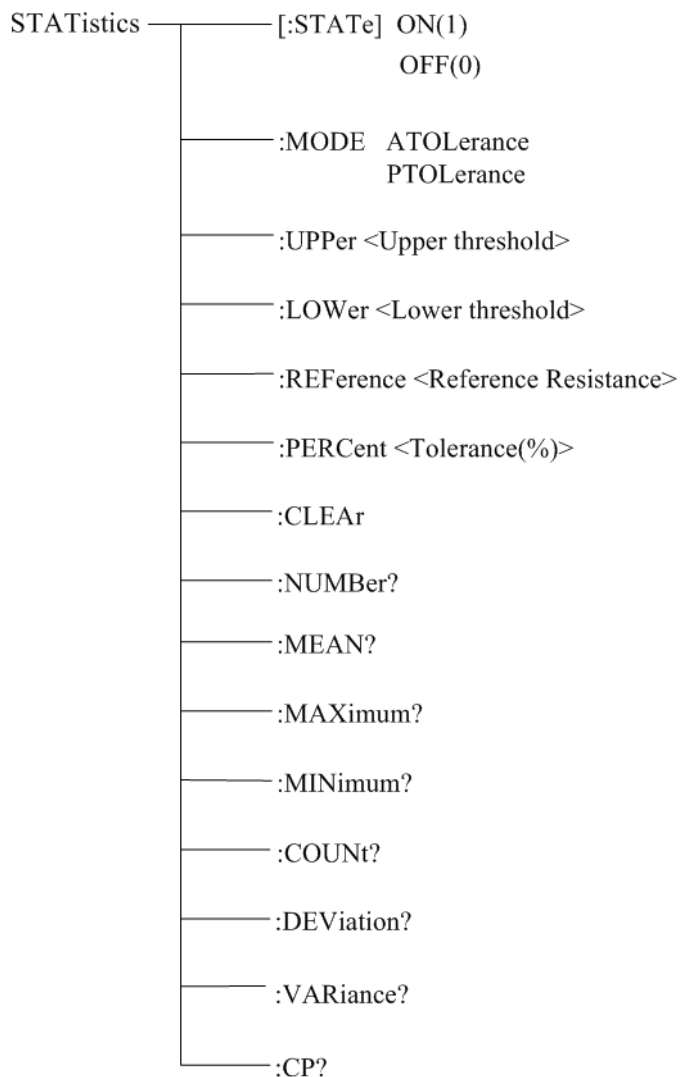

The :STATistic [:STATe] command sets the statistics state of the instrument.

The :STATistic [:STATe]? query returns to the current statistics state.

Command syntax:

: STATistics [:STATe] <ON(1) or OFF(0)>

For example: WrtCmd(":STAT:STAT ON"); Set the statistics function as "ON".

Query Syntax: : STATistics[:STATe]?

Return format: <NR1><NL^END>

<NR1> = 1 or 0

1: the current statistics function of the instrument is "ON"

0: the current statistics function of the instrument is "OFF"

The :STATistics:MODE command sets the limit mode of the instrument statistics function.

The :STATistics:MODE? query returns to the current limit mode.

Command syntax:

STATistics:MODE < ATOLerance or PTOLerance >

Where, ATOLerance: set the limit mode of the instrument statistics function as absolute tolerance mode

PTOLerance: set the limit mode of the instrument statistics function as proportional tolerance mode

For example: WrtCmd("STAT:MODE ATOL"); Set the limit mode of the instrument as absolute tolerance mode.

NOTE: If the statistics function of the instrument is "ON", ignore this command!

Query Syntax: STATistics:MODE?

Return format: <ATOL or PTOL><NL^END>

The :STATistics:UPPer command sets the upper threshold of the instrument statistics function.

The :STATistics:UPPer? query returns to the current upper threshold.

Command syntax:

STATistics:UPPer < Upper threshold >

Where,

< Upper threshold > = 0 to 2.2E+6 (NR3) the upper threshold of the statistics function unit: "Ω"

For example: WrtCmd("COMP:UPP 200"); Set the upper threshold of the statistics function as 200Ω.

NOTE: The upper threshold should be greater than or equal to the lower threshold!

If the statistics function of the instrument is "ON", ignore this command!

Query Syntax: STATistics:UPPer?

Return format: the format and unit of < Upper threshold ><NL^END> are the same as above.

The :STATistics:LOWer command sets the lower threshold of the instrument statistics function.

The :STATistics:LOWer? query returns to the current lower threshold.

Command syntax:

STATistics: LOWer< Lower threshold >

Where,

< Lower threshold > = 0 to 2.2E+6 (NR3) the lower threshold of the statistics function unit: "Ω"

For example: WrtCmd("STAT:LOW 180"); Set the lower threshold of the statistics function as 180Ω.

NOTE: The lower threshold should be less than or equal to the upper threshold!

If the statistics function of the instrument is "ON", ignore this command!

Query Syntax: STATistics:LOWer?

Return format: the format and unit of < Lower threshold ><NL^END> are the same as above.

The :STATistics:REFeRence command sets the reference resistance of the instrument statistics function.

The :STATistics:REFeRence? query returns to the current reference resistance.

Command syntax:

STATistics: REFeRence<Reference Resistance>

Where,

< Reference Resistance > = 0 to 2.2E+6 (NR3) the reference resistance of the statistics function unit: "Ω"

For example: WrtCmd("STAT:REF 20E+3"); Set the reference resistance of the instrument statistics function as 20kΩ.

NOTE: If the statistics function of the instrument is "ON", ignore this command!

Query Syntax: STATistics: REference?

Return format: the format and unit of < Reference Resistance ><NL^END> are the same as above.

The :STATistics:PERCent command sets the tolerance of the instrument statistics function.

The :STATistics:PERCent? query returns to the tolerance.

Command syntax:

STATistics:PERCent<Tolerance(%)>

Where,

< Tolerance(%) > = 0 to 99.999 (NR2) the tolerance of the statistics function unit: "%"

For example: WrtCmd("STAT:PERC 10"); Set the tolerance of the instrument statistics function as 10%.

NOTE: If the statistics function of the instrument is "ON", ignore this command!

Query Syntax: STATistics:PERCent?

Return format: the format and unit of < Tolerance(%) ><NL^END> are the same as above.

The :STATistics:CLEAr command is used to clear the statistics results (all kinds of statistics).

NOTE: If the statistics function of the instrument is "ON", ignore this command!

The :STATistics:NUMBer command is used to query the statistics numbers of statistics results.

Query Syntax: :STATistics:NUMBer?

Return format: <Total statistics numbers (NR1), valid statistics numbers (NR1)>

For example: WrtCmd(":STAT:NUMB?")

Returned value: 1256, 1243

The : STATistics:MEAN command is used to query the mean of the statistics results.

Query Syntax: :STATistics:MEAN?

Return format: <Mean (NR3) >

NOTE: When the valid statistics numbers >= 1, it will returns to the valid value or "+9.90000E+37".

For example: WrtCmd(":STAT:MEAN?")

Returned value: 1.240E+01

The : STATistics:MAXimum command is used to query the maximum of the statistics results.

Query Syntax: :STATistics:MAXimum?

Return format: <Maximum (NR3), the corresponding data serial number of the maximum data (NR1)>

NOTE: When the valid statistics numbers ≥ 1 , it will returns to the valid value or "+9.90000E+37, 0".

For example: WrtCmd(":STAT:MAX?")

Returned value: 1.2450E+01, 5

The : STATistics:MINimum command is used to query the minimum of the statistics results.

Query Syntax: : STATistics:MINimum?

Return format: <Minimum (NR3), the corresponding data serial number of the minimum data (NR1)>

NOTE: When the valid statistics numbers ≥ 1 , it will returns to the valid value or "+9.90000E+37, 0".

For example: WrtCmd(":STAT:MIN?")

Returned value: 1.2350E+01, 8

The : STATistics:COUNT command is used to query the statistics compare results.

Query Syntax: : STATistics:COUNT?

Return format: <HI count (NR1)>, <IN count (NR1)>, < LO count (NR1)>, <measurement error count (NR1)>

For example: WrtCmd(":STAT:COUNT?")

Returned value: 12, 246, 78, 5

The :STATistics:DEVIation command is used to query the statistics standard deviation.

Query Syntax: : STATistics:DEVIation?

Return format: < σ_n (NR3)>

For example: WrtCmd(":STAT:DEV?")

Returned value: 0.0159E-3

The :STATistics:VARiance command is used to query the statistics sample variance.

Query Syntax: : STATistics:VARiance?

Return format: <sn (NR3)>

For example: WrtCmd(":STAT:VAR?")

Returned value: 0.0159E-3

The :STATistics:CP command is used to query the Process Capability Index (CP).

Query Syntax: :STATistics:CP?

Return format: <Cp (NR2)>, <Cpk (NR2)>

For example: WrtCmd(":STAT:CP?")

Returned value: 0.86, 0.14

7.1.10 SYSTem Subsystem Commands

SYSTem subsystem commands are used to set the system function of the instrument, including the beeper switch, parameters save, output mode of measurement state error, parameter setting reset and so on.

Command tree:

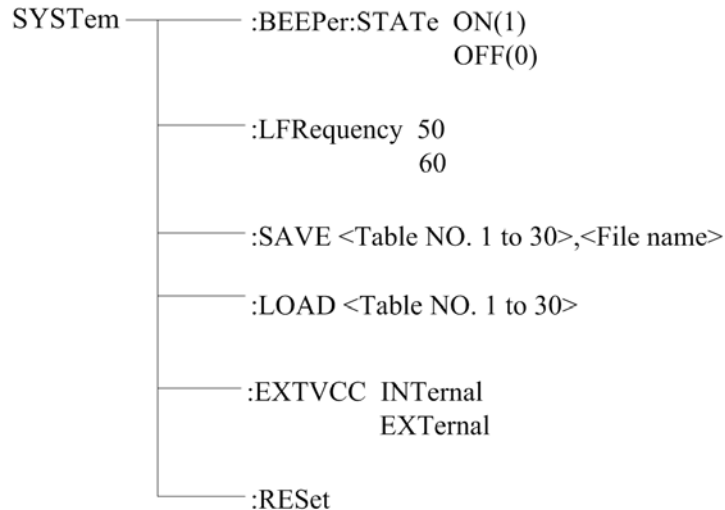

The :SYSTem:BEEPer:STATe command sets the beeper switch state of the instrument.

The :SYSTem:BEEPer:STATe? query returns to the current beeper state.

Command syntax:

```
:SYSTem:BEEPer:STATe <ON(1) or OFF(0)>
```

For example: WrtCmd(":SYST:BEEP:STAT ON"); Set the save state of the instrument as "ON".

Query Syntax: :SYST:BEEP:STAT?

Return format: <NR1><NL^END>

<NR1> = 1 or 0

1: the current beeper state of the instrument is "ON"

0: the current beeper state of the instrument is "OFF"

The :SYSTem:LFRequency command sets the line frequency of the instrument.

The :SYSTem:LFRequency? query returns to the current line frequency.

Command syntax:

```
:SYSTem:LFRequency <50 or 60>
```

For example: WrtCmd(":SYST:LFR 50"); Set the line frequency of the instrument as 50 Hz.

Query Syntax: :SYST: LFRequency?

Return format: <NR1><NL^END>

<NR1> = 50 or 60

50: the current line frequency of the instrument is "50Hz"

60: the current line frequency of the instrument is "60Hz"

The :SYSTEM:SAVE command is used to save the current parameter setting.

Command syntax:

```
:SYSTEM:SAVE <Table NO.1 to 30>, <File name>
```

Where,

<Table NO.1 to 30> = 1 to 30 (NR1), the serial number of file to be saved

<File name> the filename to be saved (no need with suffix.STA, the length of the file name should be no more than 15 characters)

For example: WrtCmd(":SYST:SAVE 9 filename"); Save the current parameter setting of the instrument to No.9 file and set the name of the file as "filename".

The :SYSTEM:LOAD command is used to load the parameter setting file saved.

Command syntax:

```
:SYSTEM:LOAD <Table NO.1 to 30>
```

Where,

<Table NO.1 to 30> = 1 to 30 (NR1) the serial number of file saved

For example: WrtCmd(":SYST:LOAD 9"); load No.9 file of parameter setting file saved.

NOTE: The file to be loaded must have been saved, otherwise ignore this command!

The :SYSTEM:EXTVCC command sets the VCC of the instrument Handler interface.

The :SYSTEM:EXTVCC? query returns to the current VCC of the instrument Handler interface.

Command syntax:

```
:SYSTEM:EXTVCC INTERNAL
EXTernal
```

Where, INTERNAL: set the VCC of the instrument Handler interface as "INTERNAL"

EXTernal: set the VCC of the instrument Handler interface as "EXTernal"

For example: WrtCmd(":SYST:EXTVCC INT"); Set the VCC of the instrument Handler interface as "EXTernal".

Query Syntax: :SYSTEM:EXTVCC?

Return format: <INT or EXT><NL^END>

INTERNAL: the current VCC of the instrument Handler interface is "INTERNAL"

EXTernal: the current VCC of the instrument Handler interface is "EXTernal"

The :SYSTEM:RESet command is used to reset the parameter setting to factory default.

Command syntax:

```
:SYSTEM:RESet
```

For example: WrtCmd(":SYSTEM:RES"); namely finish the parameter reset of the instrument.

Other Commands:

- The *RST command resets the instrument.

Command syntax: *RST

For example: WrtCmd("*RST");

- The *TRG command triggers the measurement and then sends the result to the output buffer.

Command syntax: *TRG

For example: WrtCmd("*TRG");

NOTE: "*trg" will be valid when :INIT:CONT ON and trig:sour bus commands are enabled.

- The *IDN? query returns TH2516's identification string.

Query syntax: *IDN?

Return format: <manufacturer>,<model>,<firmware><NL^END>

Where,

<manufacturer> Name of Manufacturer (Tonghui)

<model> Instrument Model (TH2516)

<firmware> Firmware Version (VER1.0.0)

For example: WrtCmd("*IDN?");

8) Handler Interface

TH2516 DC Resistance Meter equips with a Handler interface which is mainly used to output the sorting result. When the instrument is applied to an automatic component sorting test system, this interface will output the handshake signal and the sorting result output signal. The sorting result output corresponds to the comparison result output of the current comparator bin.

Terminals and Their Descriptions:

Terminal number	Terminal name	Description
1	START	Measurement trigger signal, falling edge is valid. When the instrument holds in the external trigger mode and this signal is valid, the instrument will trigger a measurement.
2	PASS2	The low bin 2 comparison result output signal will be valid.
3	FAIL	The low compare result output signal will be valid.
4	+5V	Internal +5V power output.
5	EXT_VCC	When the "Handler" power supply is set as "External", the terminal is external power source and the voltage ranges from +5V to +30V; when the "Handler" power supply is set as "Internal", the terminal is internal power source.
6	PASS1	The low bin 1 comparison result output signal will be valid.
7	PASS3	The low bin 3 comparison result output signal will be valid.
8	EOC	Measurement end signal. The low output signal will be valid.
9	EXT_GND	When the "Handler" power supply is set as "External", the terminal is external GND; when the "Handler" power supply is set as "Internal", the terminal is internal GND.

Sequence chart

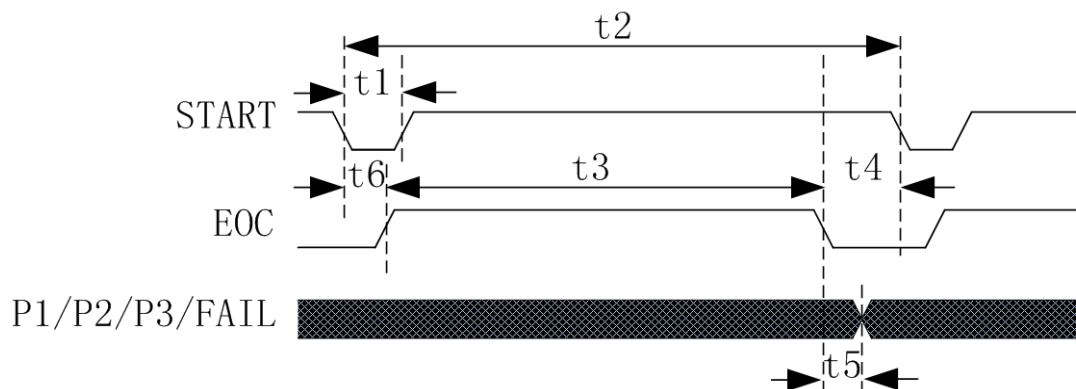

NOTE: P1/P2/P3 is PASS1/PASS2/PASS3 signal.

Time	Minimum value	Maximum value
t1: trigger pulse width	1ms	---
t2: measurement time at one time	t3+t4	---
t3: sampling time of one measurement	1 Sampling Time	---
t4: data processing and display time of one measurement	Display "ON": 22ms Display "OFF": 5ms	---
t5: end of sampling to control output time	2ms	---
t6: measurement delay time	See the setup for measurement delay	---

When OVC is OFF: Sampling Time = 5ms (50 Hz) / 5ms(60 Hz) Fast
 20 ms (50 Hz) / 16.6ms(60 Hz) Medium
 110 ms (50 Hz) / 110ms(60 Hz) Slow
 450 ms (50 Hz) / 450ms(60 Hz) Slow

When OVC is ON: Sampling Time = 10 ms + t6 (50 Hz) / 10ms + t6 (60 Hz) Fast
 40 ms + t6 (50 Hz) / 33ms + t6 (60 Hz) Medium
 220 ms + 9* t6 (50 Hz) / 220 ms + 11* t6 (60 Hz) Slow
 900 ms + 39*t6(50 Hz) / 900 ms + 47*t6(60 Hz) Slow

Electrical Characteristics

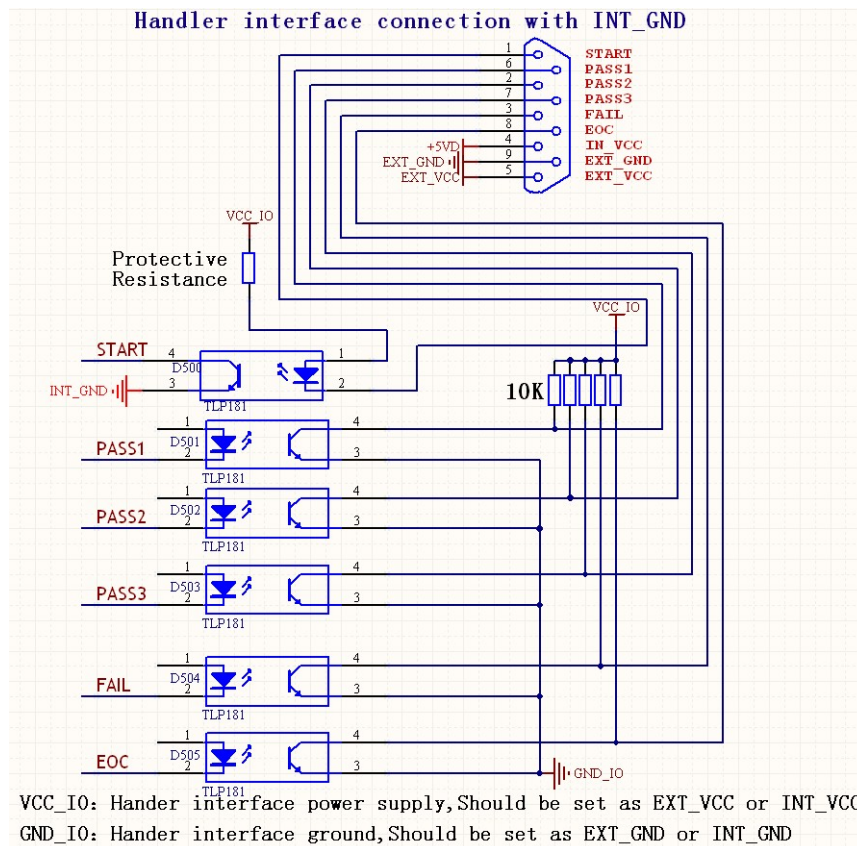

9) Package Contents and Warranty

9.1 Package Contents

Following items should be contained in the package.

Serial Number	Name	Quantity
1	TH2516 series DC Resistance Meter	1
2	TH26050A 4-terminal test cable	1
3	Three-Wire power line	1
4	PT500	1
5	Fuse of 2A	2
6	Operation Manual	1
7	Manufacturer Certificate	1
8	Test Report	1
9	Warranty Card	1

Verify that you have received all above items and any optional accessories you may have ordered. If anyone is missing, please contact our company or operating division without delay.

9.2 Marks

The following marks can be seen on each instrument panel and nameplate:

- a. Manufacturer name and trademark
- b. Product name and model
- c. Product number and date
- d. the License for Manufacturing Measurement Instruments and its number
- e. Marks for test terminal

9.3 Package

The instrument, generally wrapped in a plastic bag, should be packed in a strong packing box that could resist dust, vibration and moisture. Accessories, spare parts, operation manual and manufacturer certificates, etc. should also be included in it.

9.4 Shipping

In the shipment, the instrument should be handled with care and some precautions must be taken to resist moisture and water.

9.5 Storage

The instrument should be stored in an airy room where the environment temperature ranges from 5°C to 40°C, relative humidity is not greater than 85% and the air contains no detrimental impurities that might corrode the instrument.

9.6 Warranty

This instrument is warranted against defects in material and workmanship for a period of two years from the date of shipment. You should supply us with the warranty card before you enjoy the free maintenance service. This warranty does not apply in the event of misuse or abuse of the product or as a result of unauthorized alterations or repairs. We will, without charge, repair or replace, at its option, defective product or component parts.

The maintenance for this instrument should be performed by professional maintenance personnel. Do not substitute the internal components unauthorized when maintaining. In order to ensure the measurement accuracy, the instrument must be measured and corrected after maintenance. You should bear the maintenance expense for damages caused by unauthorized repairing or substituting components.